

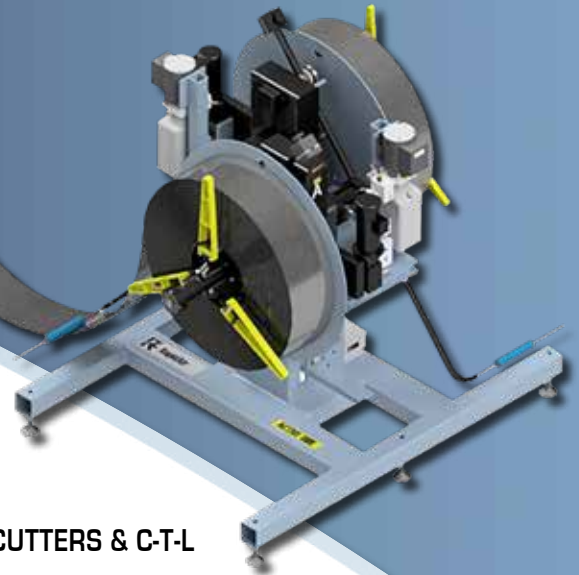

# RAPIDAIR

FEEDING &  
COIL HANDLING  
EQUIPMENT

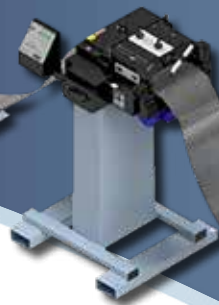
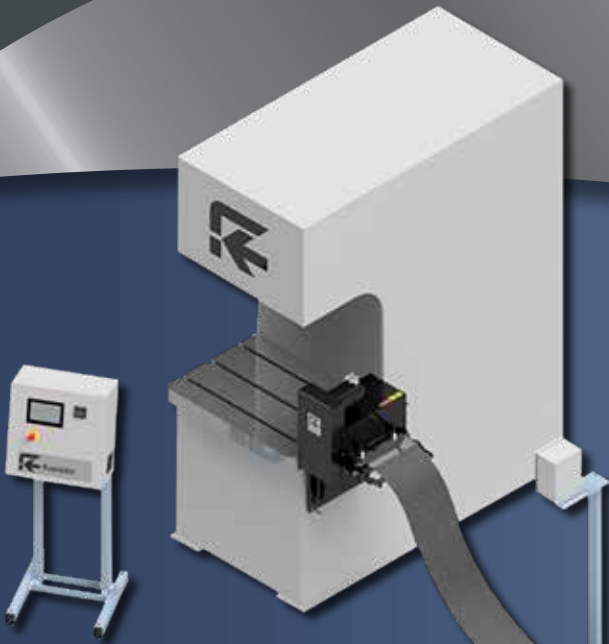

## PAYOUTS



## STRAIGHTENERS



## FEEDS



## CUTTERS & C-T-L



## LOOP CONTROLS

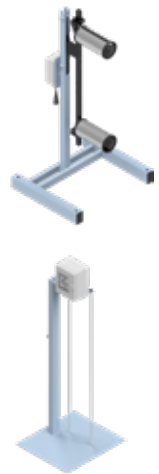

# FEEDING & COIL HANDLING EQUIPMENT

## CONTENTS

<b>COMPLETE PRODUCTION LINE</b> .....	2	<b>Stock Reels</b> .....	19 - 21
<b>INDIVIDUAL PRODUCTS</b> .....	3	<b>Specialty Stock Reels</b> .....	22 - 23
<b>Rapid-Air Feeds</b> .....	4 - 7	<b>Cutters</b> .....	24 - 25
<b>Servo Feeds</b> .....	8 - 14	<b>Cut-To-Length</b> .....	26
<b>Straighteners</b> .....	15 - 18	<b>Pallet Reels</b> .....	27
		<b>Special Requirements</b> .....	28

## COMPLETE PRODUCTION LINE

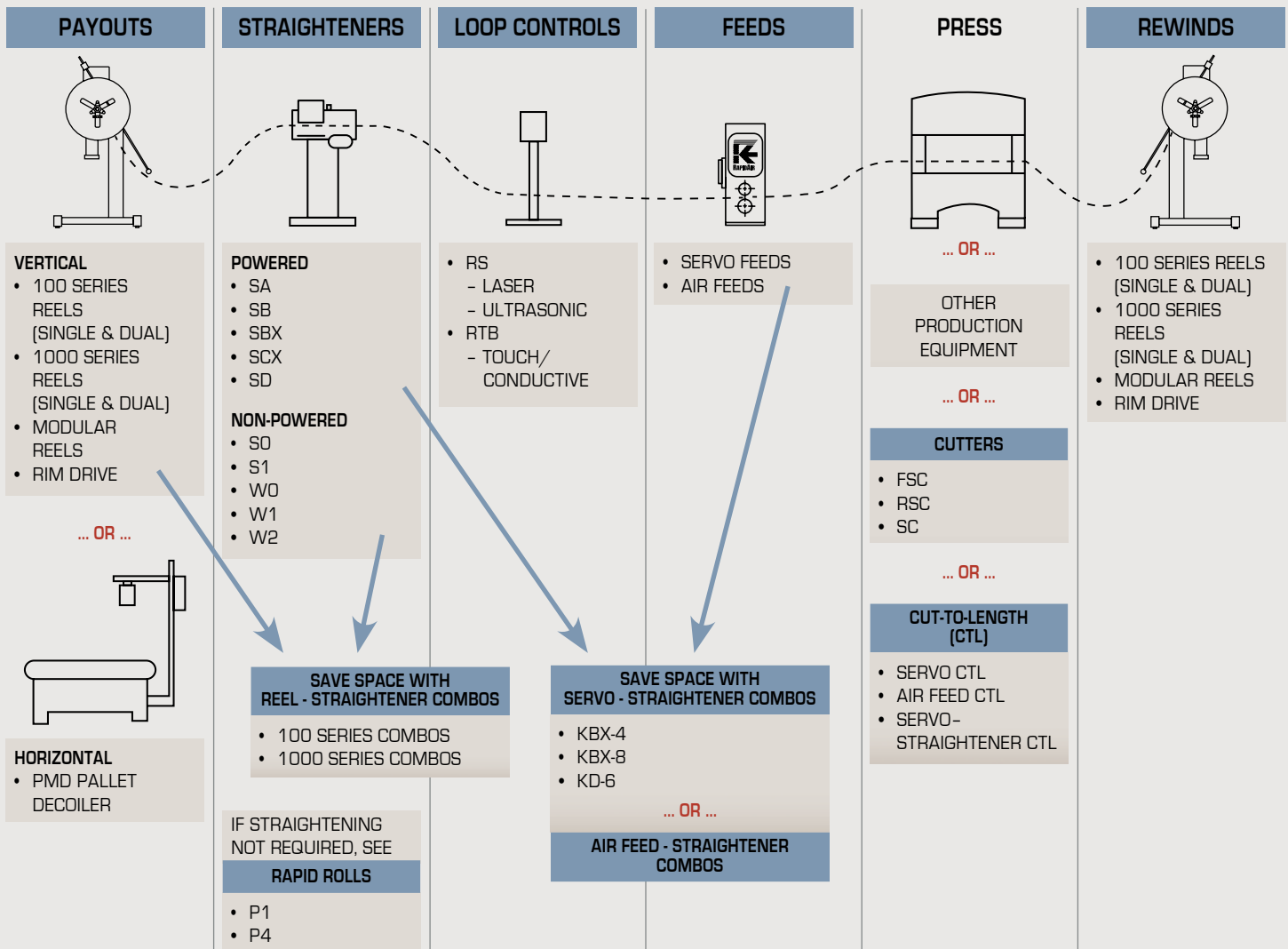

# FEEDING & COIL HANDLING EQUIPMENT

## INDIVIDUAL PRODUCTS

Easy to integrate into your existing stamping operation.

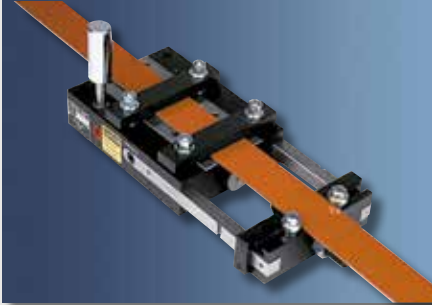

**AIR FEEDS -**  
Rapid-Air is the pioneer and still the leader. Widest selection of accessories and options anywhere.



**MINI-SERVOS -**  
So economical you can mount it on the die and leave it.



**SERVO FEEDS -**  
Redesigned. New manufacturing techniques bring you lowest cost, highest quality, lowest maintenance servo line ever.



**STAGGER FEEDS -**  
Produces the most parts from least amount of material.



**STOCK STRAIGHTENERS -**  
Patented platen is unmatched at smoothing ripples, removing coil set, setting curvature.



**STOCK REELS -**  
Flexibility, precise control, utmost reliability. Powered, non-powered. Hydraulic expansion and brakes.



**PALLET DECOILERS -**  
Leave coils on pallets and reduce handling. Precise payout for high speed, high volume.



**CUTTERS -**  
Pivoting arm for round or flat stock. Reciprocating blade for flat stock.



**DUAL SWIVEL REELS -**  
For heavy-duty coil handling. Quick changeover minimizes downtime.



**TRANSPORTERS -**  
Conveys scrap or parts quickly and economically. Compact, low under-die profile.

# AIR FEEDS

Press or Production  
Machine

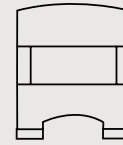

Coiled  
Stock



Feeds Coiled  
Stock

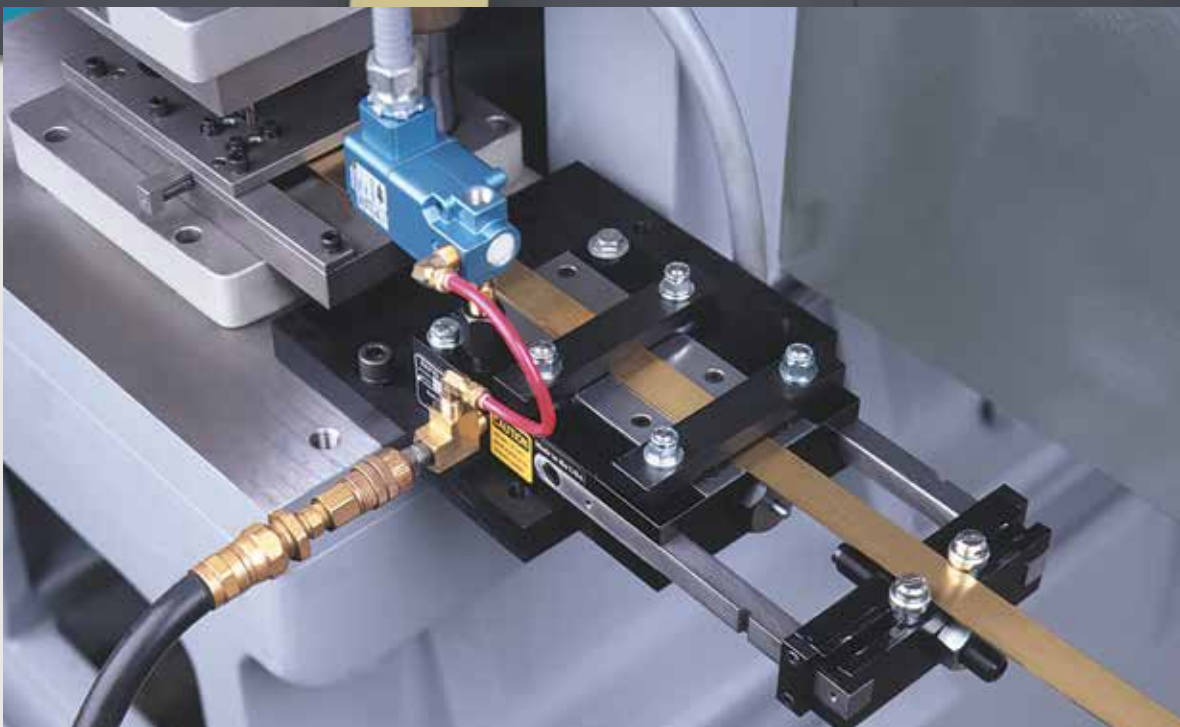

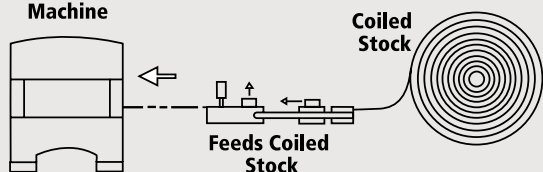

## ACCESSORIES & OPTIONS

Many options and accessories are available to feed a variety of applications including metal, wire, plastic, fabric, flat stock, round stock, extrusions, etc.



### ELECTRIC ACTUATING VALVE

An alternate to the standard actuating valve provided with each feed. Electric valve 2-way, normally open, 115 vac/60hz one size for series A & B feeds, one for Series C, D, F, H, J & W feeds, and another with quick exhaust for Series L, P, FX & LX.



### CUSTOM STOCK & FEED CLAMPS

To accommodate special material configurations, such as extrusions, delicate surfaces or soft, pliable materials. Urethane, delrin, and nylon are some of the materials available for clamp inserts.

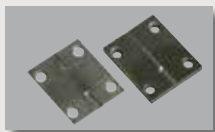

### SPECIAL WEAR PLATES

Replaceable wear plates can be grooved to accommodate special shapes and sizes.



### ANTI-BUCKLING GUIDES

Specialty designed guides to prevent buckling of very thin flat or wire stock feeding at high speeds and/or long progressions.



### BELT FEED

Enables feeds to accurately feed very limp delicate stock, including metals, teflon and other tapes, foil strips, fabrics, paper, photographic film and gasket materials. Material (even skeleton) is sandwiched between two endless belts to move it into or out of a press or other machines. **A & C models only.**

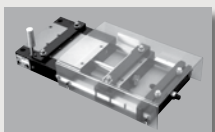

### SAFETY GUARDS

See-through high-strength plastic safety guard shields the moving mechanism. For applications where safety requirements include machine guarding.



### PILOT RELEASE STOCK CLAMP

The spring-loaded stock clamp, optional with all Rapid-Air feeds, is recommended for most applications. For unusual requirements, the pilot release stock clamp is available. An electric signal actuates the pilot release clamp so that it lifts completely to allow for free movement of stock to position material when pilots are used. Solenoid valve not included. Order separately from Rapid-Air.

AIR FEED MODEL	MAX WIDTH	MAX STROKE LENGTH*	STOCK THICKNESS**	SPEED (CYC/MIN) ***	PULLING CAPACITY ****	NET WEIGHT (LBS.)
A2 (W)	1-1/2" (38.1 mm)	2" (50 mm)	.002" to .040" (.051 to 1.02 mm)	260	20 lbs (9.1 kg)	6.4
A4 (W)		4" (101 mm)		200		8.6
A6 (W)		6" (152 mm)		160		10.8
B2 (W)	2-1/2" (63.5 mm)	2" (50 mm)	.002" to .040" (.051 to 1.02 mm)	230	20 lbs (9.1 kg)	9.1
B4 (W)		4" (101 mm)		175		12
C3	3" (76.2 mm)	3" (76 mm)	.003" to .075" (.076 to 1.91 mm)	195	45 LBS (20.5 KG)	15.6
C6		6" (152 mm)		140		18.5
C12		12" (305 mm)		85		24.3
D3	4" (101.6 mm)	3" (76 mm)	.003" to .075" (.076 to 1.91 mm)	175	45 LBS (20.5 KG)	17.9
D6		6" (152 mm)		135		22.5
W6	2" (50.8 mm)	6" (152 mm)	.003" to .090" (.076 to 2.29 mm)	140	100 lbs (45.5 kg)	22.4
W12		12" (305 mm)		85		28.4
W20		20" (508 mm)		50		34.4
F4	6" (152 mm)	4" (101 mm)	.004" to .075" (.1 to 1.91 mm)	160	100 lbs (45.5 kg)	34
F6		6" (152 mm)		130		38
F12		12" (305 mm)		70		51
F20		20" (508 mm)		35		67
H4	8" (203 mm)	4" (101 mm)	.004" to .075" (.1 to 1.91 mm)	160	100 lbs (45.5 kg)	40.5
H8		8" (203 mm)		105		51
FX6	6" (152 mm)	6" (152 mm)	.005" to .150" (.13 to 3.81 mm)	105	145 lbs (66 kg)	78
FX12		12" (305 mm)		60		91
L6	12" (305 mm)	6" (152 mm)	.005" to .090" (.13 to 2.29 mm)	105	145 lbs (66 kg)	110
L12		12" (305 mm)		60		140
P6	16" (406 mm)	6" (152 mm)	.005" to .075" (.13 to 1.91 mm)	105	145 lbs (66 kg)	120
P12		12" (305 mm)		60		150
LX12	12" (305 mm)	12" (305 mm)	.005" to .125" (.13 to 3.18 mm)	50	250 lbs (114 kg)	150

\* Electric Actuating Valve is recommended for feeds that have stroke length over 8" (203mm). Add "E" to model #.

\*\* Thinner materials and/or long strokes with thin materials possible by using anti-buckling guides. Maximum thickness capacity increases by same percentage as stock width decreases (up to max. of 150%).

\*\*\* Approximate at maximum stroke length. Heavy stock requires lower speed.

\*\*\*\* At 100 psi (6.9 bar). Includes allowance for normal friction of moving parts.

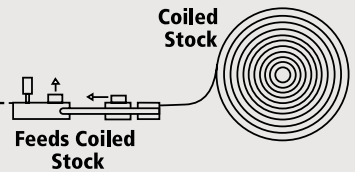
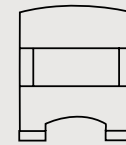

## SPECIFICATIONS AND DIMENSIONS

Model	A	B	C	D	E	F	G	H	J	K	L
A2 (W)	8.69" (220 mm)	3.22" (81 mm)	1.24" (31 mm)	3-1/2" (88 mm)	2.69" (68 mm)	3/8" (9 mm)	2.62" (66 mm)	1/8" (3 mm)	0.33" (8 mm)	1.31" (33 mm)	1/2" (12 mm)
A4 (W)	12.69" (322 mm)										
A6 (W)	16.69" (423 mm)										
B2 (W)	8.69" (220 mm)	4.22" (107 mm)	1.24" (31 mm)	3-1/2" (88 mm)	2.69" (68 mm)	3/8" (9 mm)	3.62" (91 mm)	1/8" (3 mm)	0.33" (8 mm)	1.31" (33 mm)	1/2" (12 mm)
B4 (W)	12.69" (322 mm)										
C3	12.25" (311 mm)	5-1/2" (139 mm)	1.73" (43 mm)	5-1/2" (139 mm)	4.12" (104 mm)	1/2" (12 mm)	4-1/2" (114 mm)	1/4" (6 mm)	0.39" (9 mm)	1.53" (38 mm)	5/8" (15 mm)
C6	18.25" (463 mm)										
C12	30.25" (768 mm)										
D3	12.25" (311 mm)	6-1/2" (165 mm)	1.73" (43 mm)	5-1/2" (139 mm)	4.12" (104 mm)	1/2" (12 mm)	5-1/2" (139 mm)	1/4" (6 mm)	0.39" (9 mm)	1.53" (38 mm)	5/8" (15 mm)
D6	18.25" (463 mm)										
W6	19.94" (506 mm)	5" (127 mm)	1.98" (50 mm)	5-3/4" (146 mm)	4.31" (109 mm)	0.69" (17 mm)	4-1/4" (107 mm)	1/4" (6 mm)	.53" (13 mm)	2.62" (66 mm)	9/16" (14 mm)
W12	31.94" (811 mm)										
W20	47.94" (1,217 mm)										
F4	15.62" (396 mm)	9-1/4" (234 mm)	1.98" (50 mm)	5-3/4" (146 mm)	4.31" (109 mm)	.62" (15 mm)	7-1/2" (190 mm)	1/4" (6 mm)	.66" (16 mm)	2.16" (54 mm)	9/16" (14 mm)
F6	19.62" (498 mm)										
F12	31.62" (803 mm)										
F20	47.62" (1,209 mm)										
H4	15.62" (396 mm)	11-1/4" (285 mm)	1.98" (50 mm)	5-3/4" (146 mm)	4.31" (109 mm)	.62" (15 mm)	9-1/2" (241 mm)	1/4" (6 mm)	.66" (16 mm)	2.16" (54 mm)	9/16" (14 mm)
H8	23.62" (599 mm)										
FX6	23.38" (593 mm)	10" (254 mm)	2.48" (62 mm)	7-3/8" (187 mm)	5-3/8" (136 mm)	.62" (15 mm)	8" (203 mm)	1/2" (12 mm)	.66" (16 mm)	3.84" (97 mm)	7/8" (22 mm)
FX12	35.38" (898 mm)										
L6	23.38" (593 mm)	16-1/2" (419 mm)	2.48" (62 mm)	7-3/8" (187 mm)	5-3/8" (136 mm)	1" (25 mm)	14" (355 mm)	1/2" (12 mm)	.66" (16 mm)	3.84" (97 mm)	1.53" (38 mm)
L12	35.38" (898 mm)										
P6	23.38" (593 mm)	20.48" (520 mm)	2.48" (62 mm)	7-3/8" (187 mm)	5-3/8" (136 mm)	1" (25 mm)	18" (457 mm)	1/2" (12 mm)	.66" (16 mm)	3.84" (97 mm)	1.53" (38 mm)
P12	35.38" (898 mm)										
LX12	35.38" (898 mm)	18" (457 mm)	2.98" (75 mm)	7-7/8" (200 mm)	6" (152 mm)	1" (25 mm)	14" (355 mm)	1/2" (12 mm)	.66" (16 mm)	3.59" (91 mm)	2.24" (56 mm)

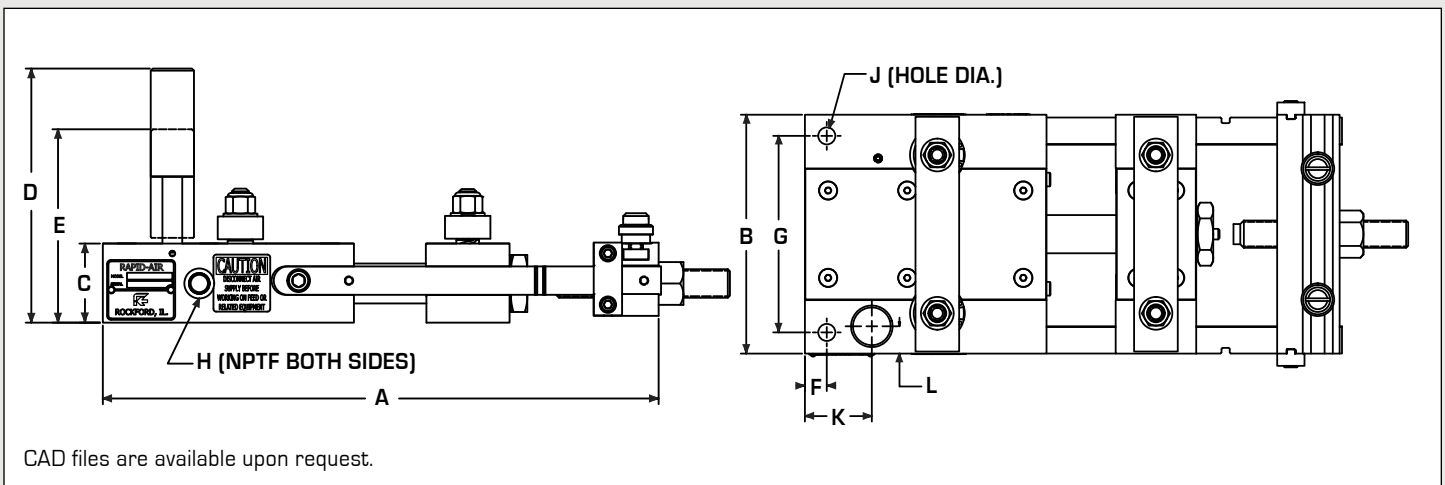

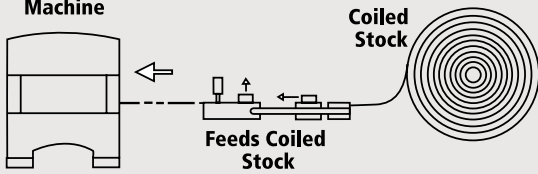

## AIR FEED OPERATING SEQUENCE

STEP	Actuating Valve Status	Stock Clamp Status	Feed Clamp Status	Slide Block Status
1	Starts Down	Closes	Closed *	Forward
2	Down	Closed	Open	Starts Retracting
3	Down	Closed	Open	Retracted
4	Starts Up	Closed *	Closes	Retracted
5	Up	Open	Closed	Feeding

\* Temporarily

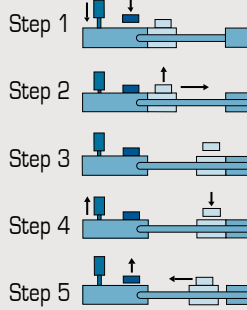

## AIR CONSUMPTION & SPEED BY MODEL

FEED AIR CONSUMPTION

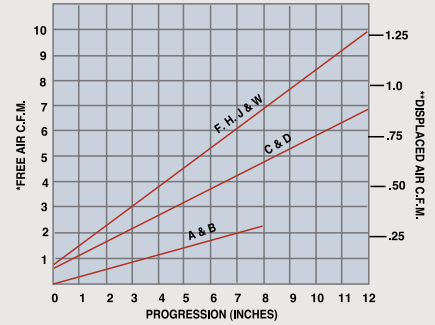

FEED AIR CONSUMPTION

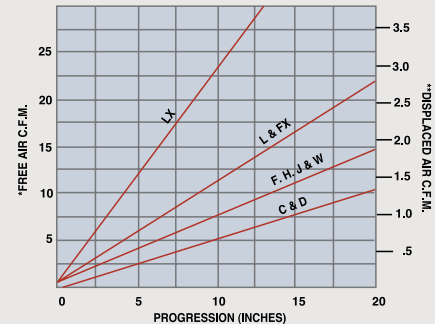

SPEED VS. PROGRESSION

The following graph indicates recommended maximum speeds anticipated for various progressions within each feed series (using an average stock thickness for each series). Feeding heavier stock would lower the maximum speed limit accordingly.

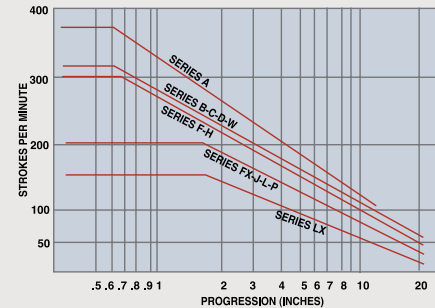

### ADD-ON FLAT STOCK AND WIRE STRAIGHTENERS FOR AIR FEEDS.

Models SO and WO can be attached to our air feeds for special light duty applications.

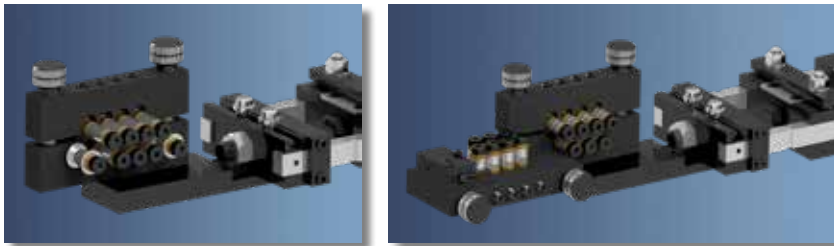

## CUSTOM AIR FEEDS FOR YOUR SPECIFIC APPLICATION



## MODEL TC3 & TW6 TRANSPORTERS

- Conveys scrap or parts quickly and economically.
- Crisp, sharp tray action shuffles parts off faster.
- Eliminates costly conveyors and belt replacement.
- Compact low profile for better clearance.
- Easily mounted. Perfect for tight areas.
- Low cost, long life wear parts.
- Low maintenance.
- Precision designed and built with the same rugged reliability as our Rapid-Air feeds.
- Air pressure operating range 20 to 80 psi (1.4 to 5.5 bar). Easy access speed adjustment screw for fine tuning.
- Easily moves 10 lbs. (4.5kg) at 40 psi (2.8 bar) air pressure.
- Accepts higher pressures for heavier loads.
- Special shuttle trays, tray surfaces and accessories available.
- Convey high temperature parts.

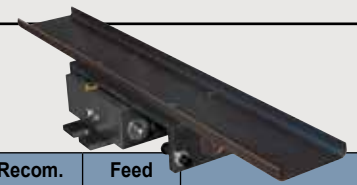

Model	Load Capacity	Recom. Speed SPM (adj)	Feed Rate (per min)	Air Pressure Range
TC3	10 lbs (4.5kg)	175	300" (7.6m)	20-80 psi (1.4 - 5.5 bar)
TW6	20 lbs (9.0kg)		350" (8.9m)	

# SERVO FEEDS

Press or Production  
Machine

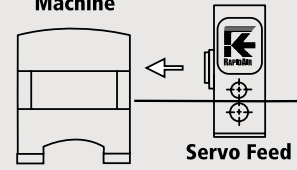

Coiled  
Stock

■ MS, 100D, 100T, 200T, 200TX, 400T, WS500, STF  
FOR FAST, ACCURATE, REPEATABLE PRODUCTION.

MS SERIES - MS8, MS4, & MS2





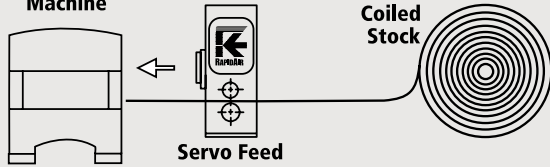

## MODEL SELECTION

HOW TO SELECT THE RAPID-AIR SERVO FEED MODEL THAT IS RIGHT FOR YOU.

Primary considerations in selecting a servo feed should be material thickness, width and press speed.

## SERVO CONTROL

- 100 Job storage (first 25 are multi-sequence)
- Tilttable Control

ADD-ONS INCLUDE:

- Serial Feed Interface
- GAG output expansion
- Remote Jog Pendant
- Multi Stroke Program



SERVO MODEL	MAX WIDTH	MAX THICKNESS	MAX ROLL OPENING	STANDARD ROLL TYPE	AC INPUT REQUIRED
MS2	2" (51 mm)	.04" (1.02 mm)	.060" (1.52 mm)	Hardened & Ground	115V 1 ph 60 Hz (Hummer is 230V)
MS4	4" (102 mm)				
MS8	8" (203 mm)				
MS Series also available in Hummer (high speed) and Smart (upgraded control) versions					
106D	6" (152 mm)	.085" (2.15 mm)	.150" (3.81 mm)	Hardened & Ground	115V 1 ph 60 Hz
112D	12" (305 mm)	.060" (1.52 mm)			
118D	18" (457 mm)	.045" (1.14 mm)			
106T	6" (152 mm)	.105" (2.66 mm)	.150" (3.81 mm)	Hardened & Ground	230V 3 ph 60 Hz
112T	12" (305 mm)	.080" (2.03 mm)			
118T	18" (457 mm)	.065" (1.65 mm)			
208T	8" (203 mm)	.105" (2.66 mm)	.180" (4.57 mm)	Hardened & Ground	230V 3 ph 60 Hz
212T	12" (305 mm)	.095" (2.41 mm)			
218T	18" (457 mm)	.085" (2.15 mm)			
224T	24" (610 mm)	.075" (1.91 mm)			
208TX	8" (203 mm)	.125" (3.18 mm)	.180" (4.57 mm)	Hardened & Ground	230V 3 ph 60 Hz
212TX	12" (305 mm)	.125" (3.18 mm)			
218TX	18" (457 mm)	.100" (2.54 mm)			
224TX	24" (610 mm)	.100" (2.54 mm)			
412T	12" (304 mm)	.1875" (4.76 mm)	.250" (6.35 mm)	Hardened & Ground	480V 3 ph 60 Hz

## CUSTOM CONTROLS & PROGRAMMING AVAILABLE



# SERVO FEEDS

Press or Production Machine

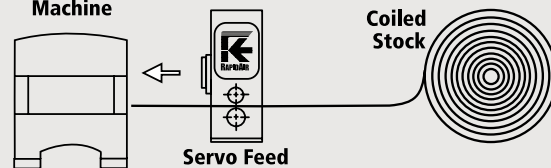

## DIMENSIONS

### MINI-SERVO

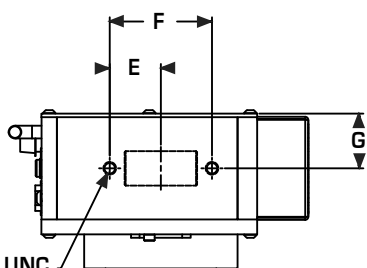
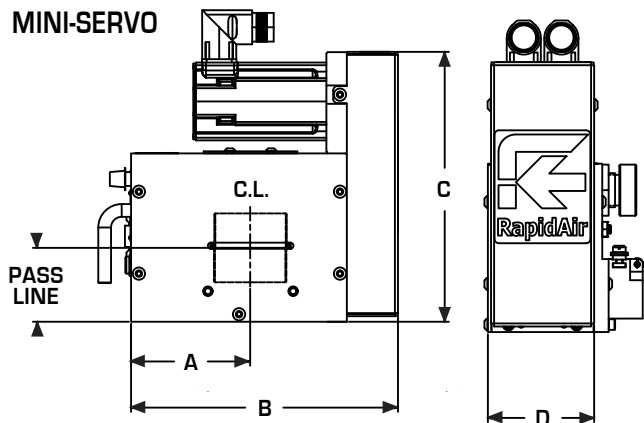

(2) 3/8-16 UNC

Servo Model	Pass Line	A	B	C	D	E	F	G
MS2		3-1/2" (89 mm)	7-13/16" (198 mm)					
MS4	2.17" (55.12 mm)	4-1/2" (114 mm)	9-7/8" (250 mm)	7-15/16" (202 mm)	3-1/8" (79 mm)	1-1/2" (38.1 mm)	3" (76.2 mm)	1-5/8" (41 mm)
MS8		6-1/2" (165 mm)	13-13/16" (351 mm)					

Dimensions are the same for MS Hummer, MS Smart, & Mighty Mini

CAD files are available upon request.

### 200T & TX

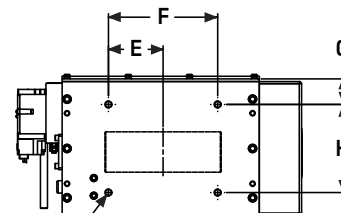
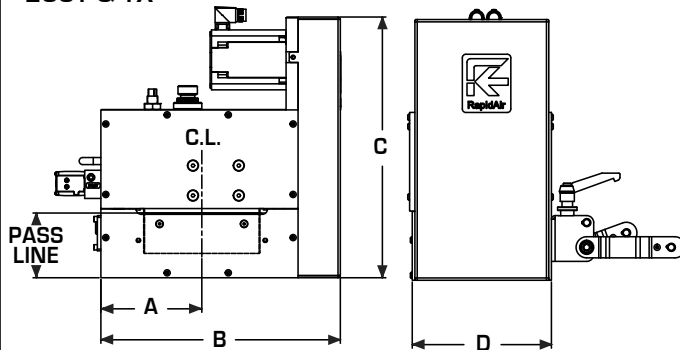

(4) 1/2-13 UNC

Servo Model	Pass Line	A	B	C	D	E	F	G	H
208T(X)		7-5/32" (182 mm)	17" (432 mm)						
212T(X)	4.59" (116.6 mm)	9-5/32" (233 mm)	21" (533 mm)	18-1/2" (467 mm)	9-7/8" (251 mm)	3-7/8" (98 mm)	7-3/4" (196.9 mm)	1-13/16" (46 mm)	6-1/4" (158.8 mm)
218T(X)		12-5/32" (309 mm)	27" (686 mm)						
224T(X)		15-5/32" (385 mm)	33" (838 mm)						

CAD files are available upon request.

### 412T

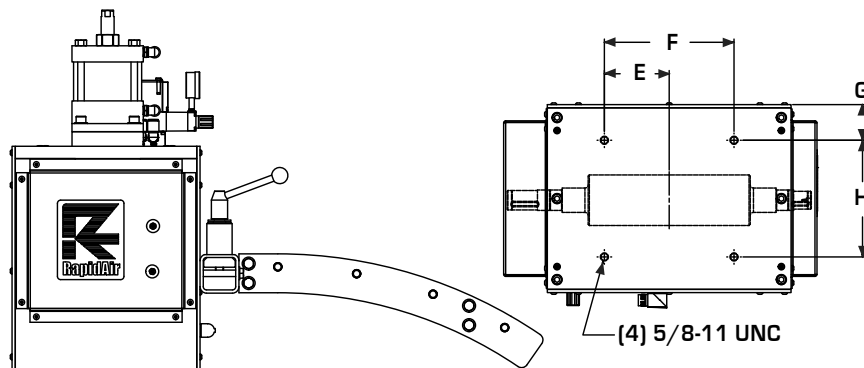
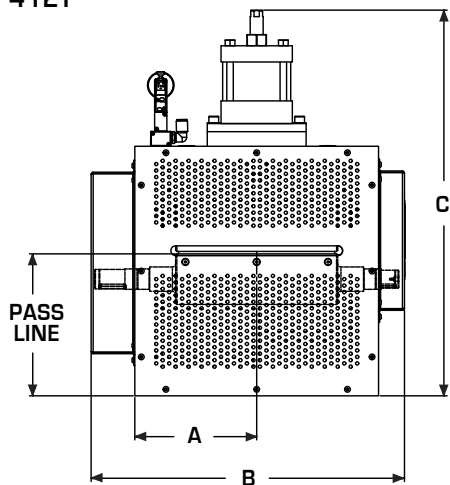

(4) 5/8-11 UNC

Servo Model	Pass Line	A	B	C	D	E	F	G	H
412T	10.95" (278.1 mm)	9-3/8" (238 mm)	24-5/32" (614 mm)	29-3/4" (756 mm)	14-1/2" (368 mm)	5" (127 mm)	10" (254 mm)	2-3/4" (70 mm)	9" (228.6 mm)

CAD files are available upon request.

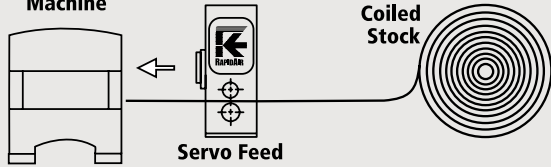

## DIMENSIONS

100D & T

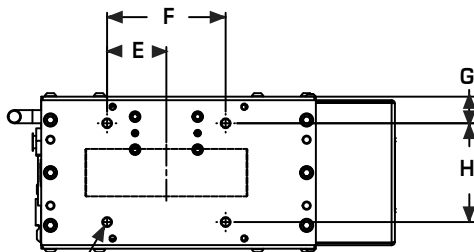
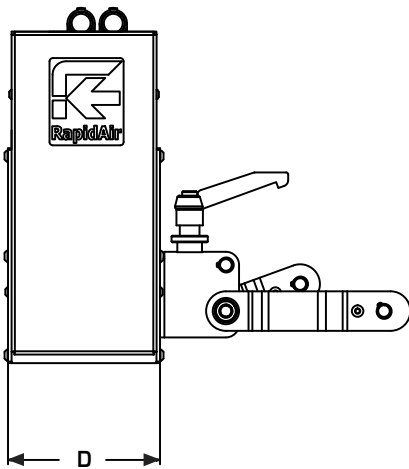
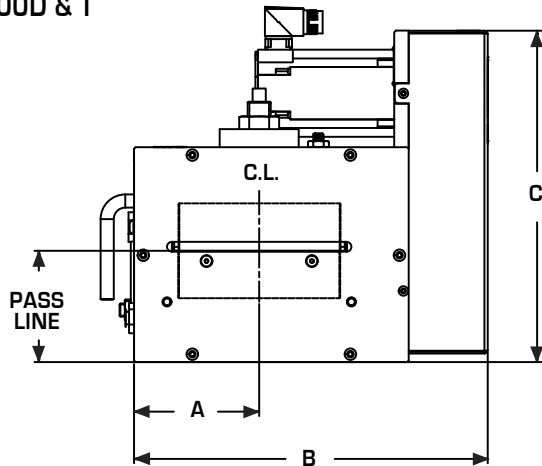

(4) 3/8-16 UNC

Servo Model	Pass Line	A	B	C	D	E	F	G	H
106D(T)	4.22" (107.2 mm)	4-3/4" (121 mm)	13-7/16" (341 mm)	12-9/16" (319 mm)	5-3/4" (146 mm)	2-1/4" (57 mm)	4-1/2" (114.3 mm)	1" (25.4 mm)	3-3/4" (95.3 mm)
112D(T)		7-3/4" (197 mm)	19-7/16" (494 mm)						
118D(T)		10-3/4" (273 mm)	25-7/16" (646 mm)						

CAD files are available upon request.

WS500

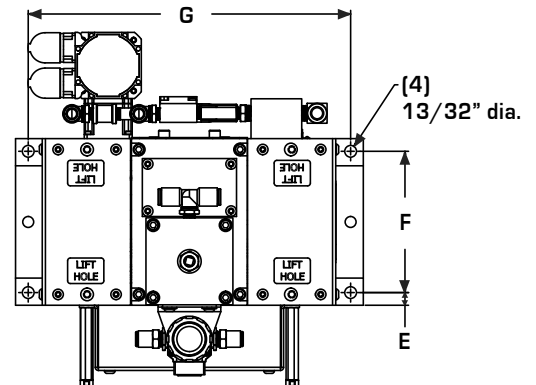
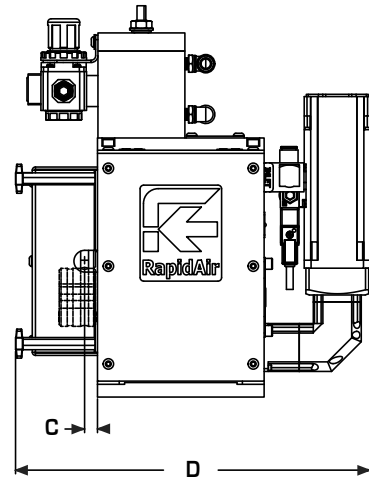
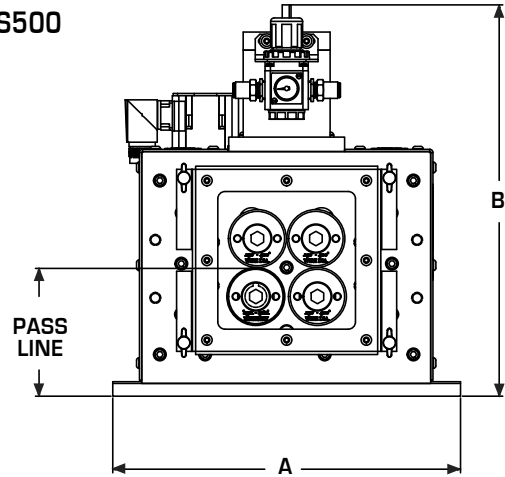

Servo Model	Pass Line	A	B	C	D	E	F	G
WS500	4.41" (112 mm)	12" (305 mm)	13-1/2" (343 mm)	.45" (11.4 mm)	12-1/4" (311 mm)	7/16" (11.1 mm)	4-7/8" (124 mm)	11-1/8" (282.6 mm)

CAD files are available upon request.

# SERVO FEEDS

Press or Production Machine



## PERFORMANCE DATA

THEORETICAL MAX SPM CAPACITY VERSUS FEED LENGTH FOR GIVEN FEED WINDOW PER SYSTEM (WITHOUT PILOT RELEASE). THIS IS TRACTION LIMITED AND SERVES ONLY AS A GUIDELINE. CONTACT SALES OR ENGINEERING FOR OTHER FEED WINDOWS

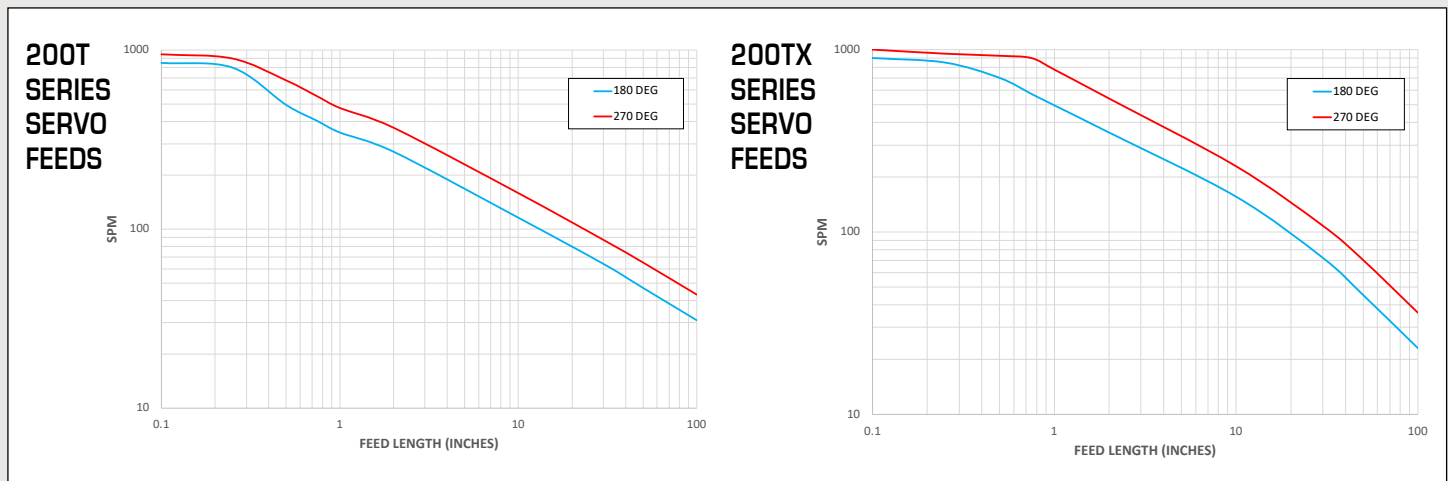
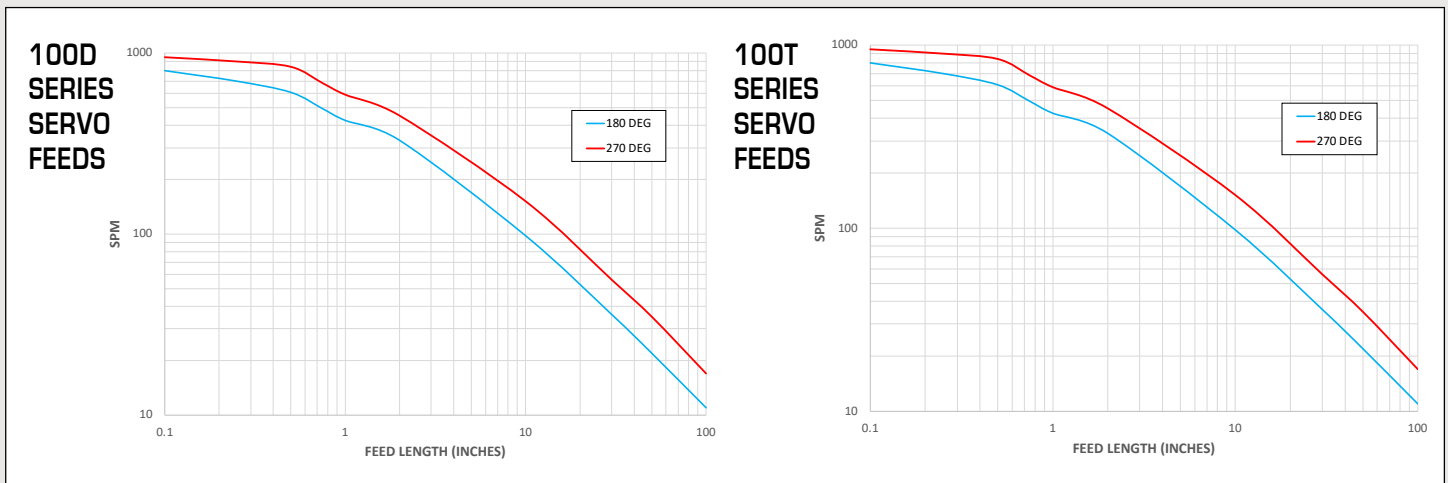
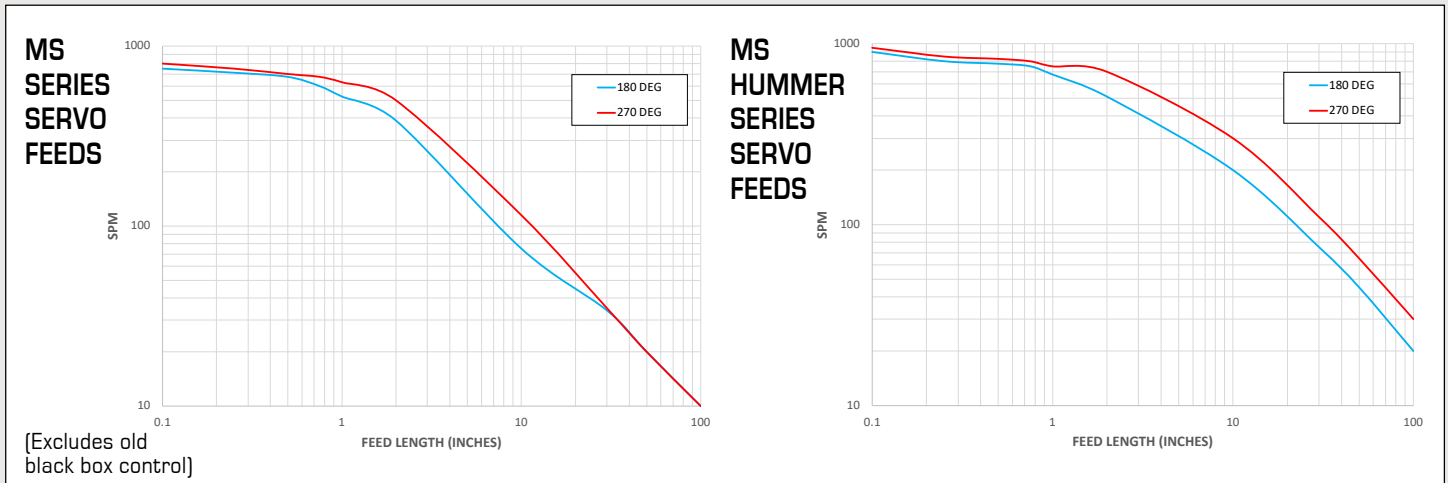

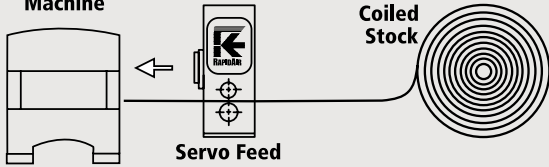

## PERFORMANCE DATA

THEORETICAL MAX SPM CAPACITY VERSUS FEED LENGTH FOR GIVEN FEED WINDOW PER SYSTEM (WITHOUT PILOT RELEASE). THIS IS TRACTION LIMITED AND SERVES ONLY AS A GUIDELINE. CONTACT SALES OR ENGINEERING FOR OTHER FEED WINDOWS

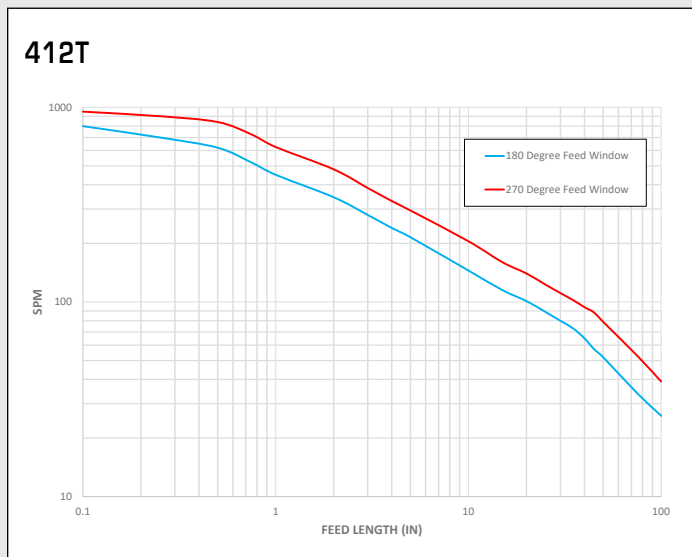
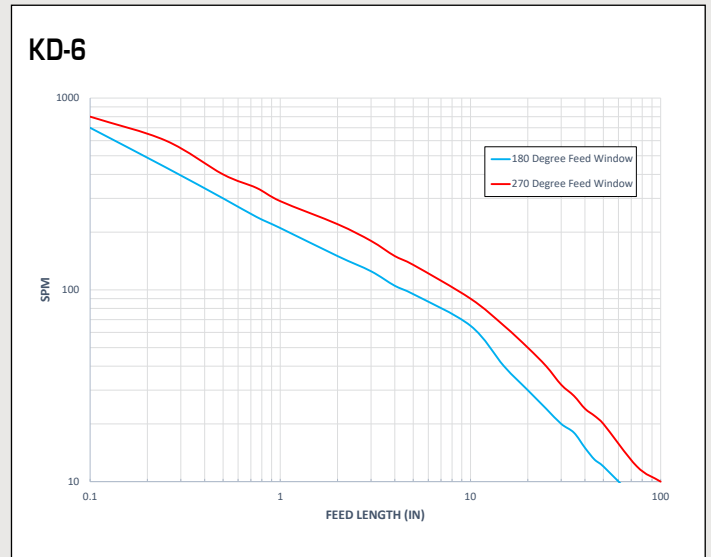
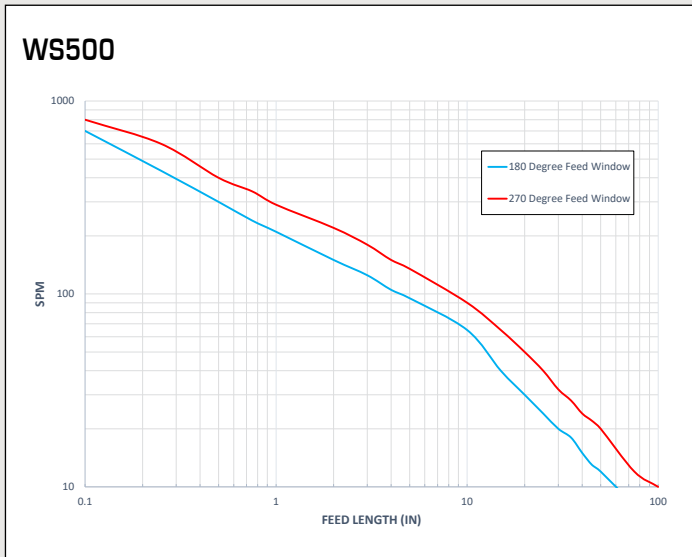

## ADJUSTABLE MOUNTING BRACKETS

Available for all models.

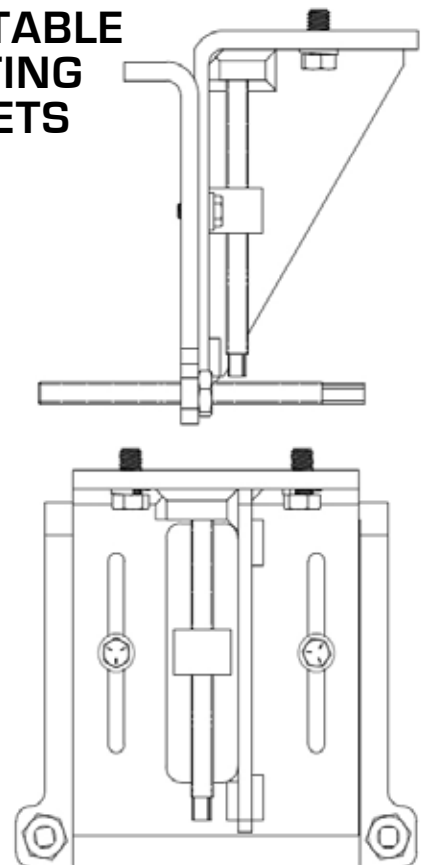

CAD files are available upon request.

# SERVO FEEDS

Press or Production Machine

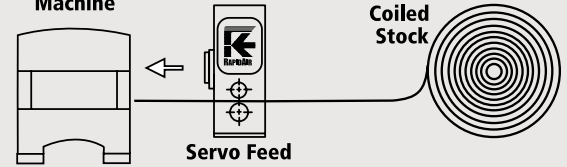

## SERVO DRIVE STAGGER FEED STF6

PRODUCES THE MOST PARTS FROM THE LEAST AMOUNT OF MATERIAL

Rapid-Air's STF Series Servo Drive Stagger Feed maximizes material usage by pre-programming the optimum pattern to reduce coil material waste. Enhances even the most simple die by feeding it diagonally, side-to-side, or in any pattern.

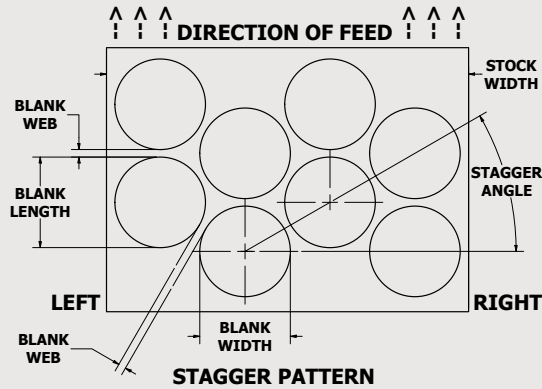

SERVO MODEL	MAX WIDTH	MAX THICKNESS	LATERAL MOVE	STANDARD ROLL TYPE	AC INPUT REQUIRED
STF6	6" (152 mm)	.105" (2.15 mm)	0" to 6" (0-152 mm)	Shot Blasted Hardened & Ground	230V, 1 ph, 60 Hz

## TANDEM SERVO FEEDS

IDEAL FOR FEEDING THIN OR VERY FLEXIBLE MATERIALS

Recommended when feeding thin or very flexible material into a die. Two synchronized feeds prevent buckling by maintaining tension on the stock using a special program. Primary Servo Feed is placed at entrance to the die and Secondary Servo Feed is placed at exit.

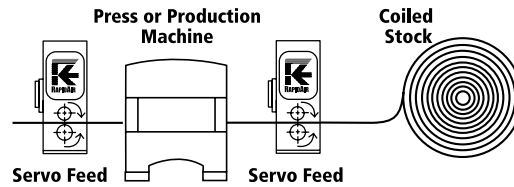

## SERVO FEED / STRAIGHTENER COMBOS

SAVE FLOOR SPACE AND ECONOMIZE

\* Pilot Release not available on Servo-Straighteners.

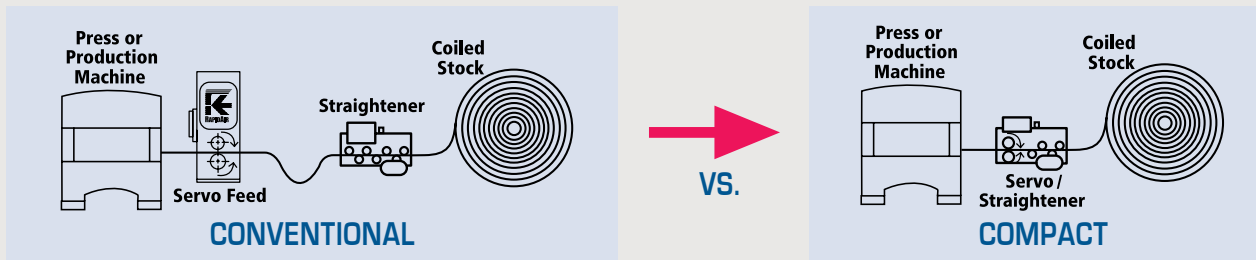

SERVO STRAIGHTENER MODEL	MAX WIDTH	STRAIGHTENING RANGE	STANDARD ROLL TYPE	AC INPUT REQUIRED
KBX-4	4" (102 mm)	.004" to .080" (.10 to 2.03 mm)	Hardened & Ground	230V, 1 ph, 60 Hz
KBX-8	8" (203 mm)	.004" to .070" (.10 to 1.78 mm)		
KD-6	6" (152 mm)	.006" to .125" (.15 to 3.18 mm)	Hardened & Ground	480V, 3 ph, 60 Hz

# STRAIGHTENERS

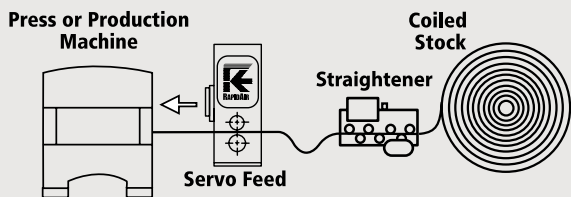

## ■ SA, SB, SBX, SCX, SD

### POWERED STOCK STRAIGHTENERS FOR SUPERIOR COIL SET REMOVAL

Simple to operate. Rapid-Air high-performance straighteners are simple to operate and capable of processing an exceptionally wide range of stock widths and thicknesses. They combine precision coil set removal with smooth payout of material. Easy to load and run, they're built with traditional Rapid-Air ruggedness for demanding, continuous use.

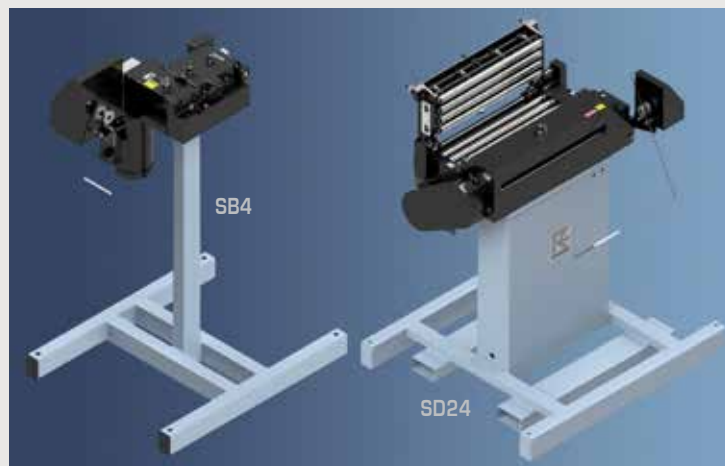

# STRAIGHTENERS

Press or Production Machine

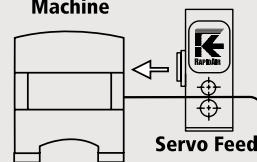

Coiled Stock

Straightener

Servo Feed

## MODEL SELECTION AND DIMENSIONS

MODEL	MAX MATERIAL WIDTH	EFFECTIVE STRAIGHTENING RANGE	MAX SPEED INCHES/MIN	AC INPUT POWER REQUIRED
SA3	3" (76 mm)	.002" - .030" (.051 - .76 mm)	700" (1,778 cm)	1/4 hp, 115 vac, single phase
SA3M			1,400" (3,556 cm)	1/2 hp, 115 vac, single phase
SB4	4" (102 mm)	.003" - .050" (.076 - 1.27 mm)	700" (1,778 cm)	1/2 hp, 115 vac, single phase
SB4M			1,400" (3,556 cm)	
SBX4	4" (102 mm)	.004" - .080" (.10 - 2.03 mm)	825" (2,100 cm)	3/4 hp, 115 vac, single phase
SBX8	8" (203 mm)	.004" - .070" (.10 - 1.78 mm)		
SBX12	12" (305 mm)	.004" - .060" (.10 - 1.52 mm)		
SBX4M	4" (102 mm)	.004" - .080" (.10 - 2.03 mm)	1,650" (4,200 cm)	1 hp, 115 vac, single phase
SBX8M	8" (203 mm)	.004" - .070" (.10 - 1.78 mm)		
SBX12M	12" (305 mm)	.004" - .060" (.10 - 1.52 mm)		
SBX12M	12" (305 mm)	.004" - .060" (.10 - 1.52 mm)		
SCX6	6" (152 mm)	.006" - .100" (.15 - 2.54 mm)	825" (2,100 cm)	1 hp, 115 vac, single phase
SCX12	12" (305 mm)	.006" - .090" (.15 - 2.29 mm)		
SCX18	18" (457 mm)	.006" - .080" (.15 - 2.03 mm)		
SCX24	24" (610 mm)	.006" - .065" (.15 - 1.65 mm)		
SCX6M	6" (152 mm)	.006" - .100" (.15 - 2.54 mm)	1,650" (4,200 cm)	2 hp, 230 vac, single phase
SCX12M	12" (305 mm)	.006" - .090" (.15 - 2.29 mm)		
SCX18M	18" (457 mm)	.006" - .080" (.15 - 2.03 mm)		
SCX24M	24" (610 mm)	.006" - .065" (.15 - 1.65 mm)		
SCX24M	24" (610 mm)	.006" - .065" (.15 - 1.65 mm)		
SCX6H	6" (152 mm)	.006" - .080" (.15 - 2.03 mm)	4,100" (10,400 cm)	3 hp, 230 vac, single phase
SCX12H	12" (305 mm)	.006" - .070" (.15 - 1.78 mm)		
SCX18H	18" (457 mm)	.006" - .060" (.15 - 1.52 mm)		
SCX24H	24" (610 mm)	.006" - .055" (.15 - 1.40 mm)		
SD6	6" (152 mm)	.006" - .125" (.15 - 3.18 mm)	825" (2,100 cm)	2 hp, 230 vac, single phase
SD12	12" (305 mm)			
SD18	18" (457 mm)			
SD24	24" (610 mm)			
SD24	24" (610 mm)			

Straightening range based on low carbon steel, commercial grade.

## RAPID-ROLL POWER ROLLS

### AN IDEAL PULLING SOURCE

If you don't need straightening capabilities, but do require a pulling source to maintain a free loop for consistent feeding, Rapid-Roll is the answer. Many different models are available to meet flat or wire stock requirements.

MODEL	MAX MATERIAL WIDTH	RECOMMENDED OPERATING RANGE	MAX SPEED INCHES/MIN	AC INPUT POWER REQUIRED
P1V	1-1/2" (38 mm)	.0005" - .075" (.0127 - 1.91 mm)	700" (1,778 cm)	1/4 hp, 115 vac, single phase
P1M			1,400" (3,556 cm)	1/2 hp, 115 vac, single phase
P4V	4" (102 mm)	.0005" - .060" (.0127 - 1.52 mm)	700" (1,778 cm)	1/4 hp, 115 vac, single phase
P4M			1,400" (3,556 cm)	1/2 hp, 115 vac, single phase
P1W	Wire	Ø.024" - Ø.150" (.127 - 3.81 mm)	700" (1,778 cm)	1/4 hp, 115 vac, single phase
P1WM			1,400" (3,556 cm)	1/2 hp, 115 vac, single phase

## EXPAND YOUR STRAIGHTENING CAPABILITIES

**Standard material flow direction.**  
SA and SB straighteners flow left to right. SBX, SCX and SD straighteners flow right to left.



All models are available with opposite flow direction. Specify when ordering. Factory convertible.

### Entrance/exit cascade rolls.

Fully adjustable entrance and/or exit cascade rolls are available for all models.

### Optional heavy-duty dancer arm.

Dancer arm with adjustable counterweight available for SCX and SD models.

### Optional loop controls.

All straightener models are equipped with an external plug connector which allows simple connection of the Rapid-Air loop control systems.

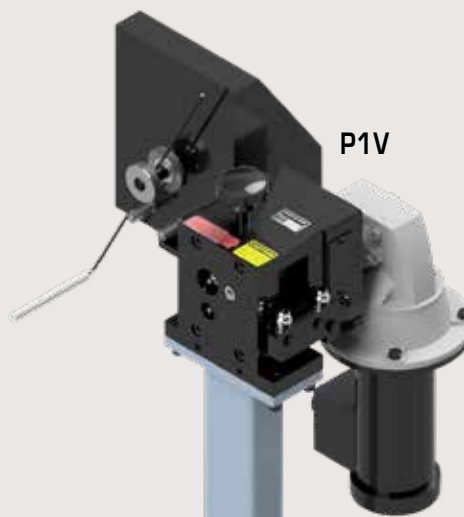



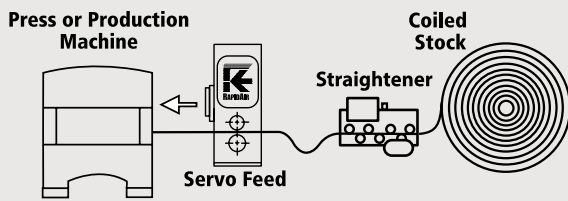

## PATENTED PLATEN STRAIGHTENER FEATURE

**RAPID-AIR STRAIGHTENERS ARE UNMATCHED AT SMOOTHING RIPPLES, REMOVING COIL SET, AND SETTING THE AMOUNT AND DIRECTION OF CURVATURE**

The traditional straightener operates by vertically adjusting a straightening roll between two opposing rolls as illustrated in Figure 1 below.

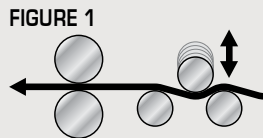
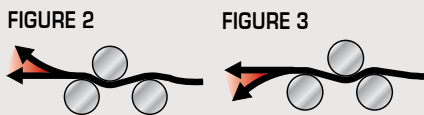
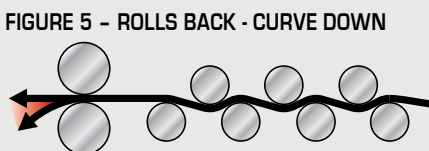
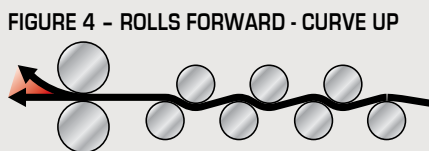

Figure 2 illustrates a forward position of the straightening roll with the resulting upward curve of material. Figure 3 illustrates a rear position of the straightening roll with the resulting downward curve to the material.



Additional rolls are added to better smooth ripples in material as illustrated in Figures 4 & 5 below.



### Six-way upper roll adjustment:

After manufacturing straighteners with vertically adjustable rolls for many years, Rapid-Air developed and patented the adjustable platen type straightener as illustrated in Figure 6.

Roll position indicators are built into the side of the adjustable platen - eliminates the need for dial-type indicators.

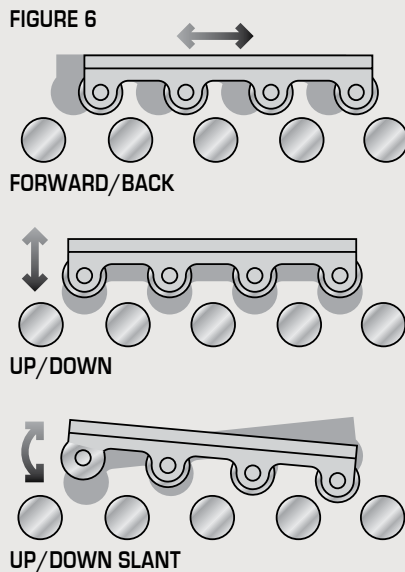
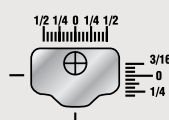

### Advantages:

The high degree of flexibility afforded by the adjustable platen design provides a predictable straightening method for a wide variety of materials and takes a lot of the "Black Magic" out of pressroom straightener setup.

### Roll diameter:

The smaller the roll diameter in a straightener, the better it is able to

remove distortions in the strip of material. But this factor is compromised by the requirement of larger rolls in wider models of straighteners in order to prevent deflection of the rolls themselves. Rapid-Air straighteners are designed to optimize all factors (including number of rolls, diameter and position) within the published material capacities and specifications for each model.

### Counter-balanced, swing-open top:

Rapid-Air pioneered the swing-open top in order to facilitate cleaning of rolls and threading of a new strip of material. For convenience and safety, each top is counter-balanced and held in the open position until it is clamped for operation. Roll adjustment settings are maintained when the top is closed and locked.

### Outperforms competitive makes.

Within rated thickness capacities Rapid-Air straighteners will outperform competitive makes that rely on traditional vertically adjustable rolls or those with simple two-point bank adjustment - including many of the expensive 17 or 21 roll varieties.

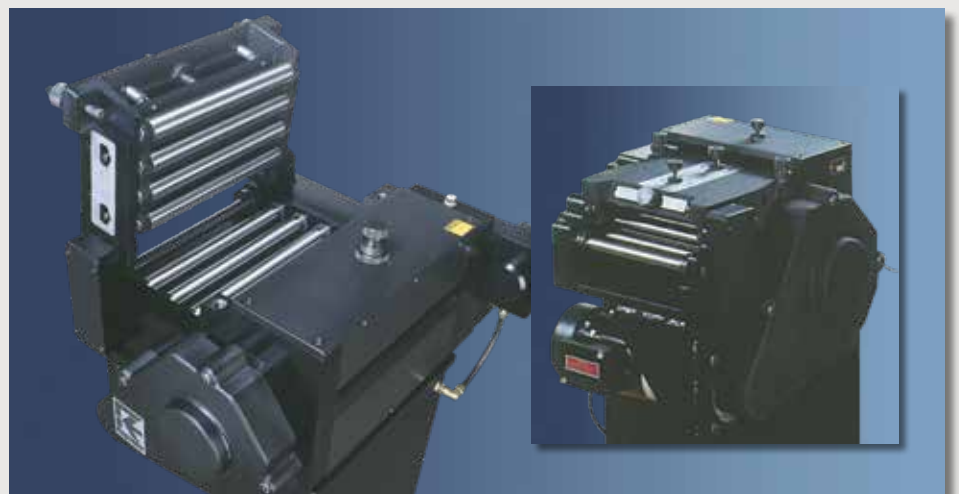

# STRAIGHTENERS

Press or Production Machine

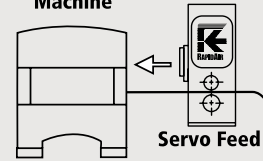

Coiled Stock

Straightener

Servo Feed

## NON-POWERED PULL THROUGH STRAIGHTENERS

EXTEND THE VERSATILITY OF A RAPID-ROLL POWER ROLL

Two flat stock straightener and three wire straightener models extend the versatility of Rapid-Roll power units. Stock can be pulled through each of these straighteners using a Rapid-Roll unit as a pulling source.

MODEL	ROLL DIAMETER	RECOMMENDED OPERATING RANGE	MAX MATERIAL WIDTH
S0	.375" (9.53 mm)	.003" - .020" (.076 - .51 mm)	1/2" (12.7 mm)
S1	.718" (18.24 mm)	.005" - .035" (.127 - .89 mm)	1-1/2" (38 mm)

### Model S0

- Flat stock.
- 1 entrance guide roll.
- [7] .375" (9.5mm) diameter straightening rolls.
- Unit separates in middle for easy loading.

CAD files are available upon request.

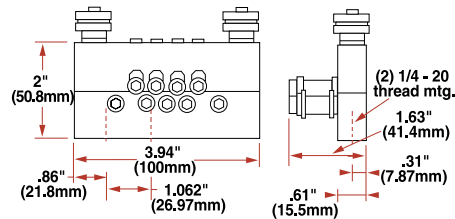

### Model S1

- Flat stock.
- 2 entrance guide rolls.
- [6] .718" [18.2mm] diameter straightening rolls.

CAD files are available upon request.

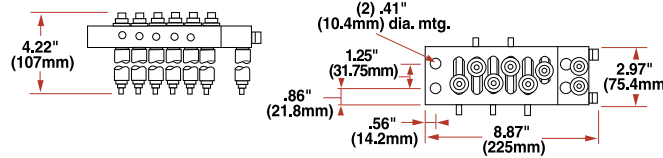

MODEL	ROLL DIAMETER	RECOMMENDED OPERATING RANGE
W0	.375" (9.53 mm)	.003" - .030" dia (.076 - .76 mm dia)
W1	.900" (22.86 mm)	.015" - .060" dia (.38 - 1.52 mm dia)
W2	1" (25.4 mm)	.050" - .150" dia (1.27 - 3.81 mm dia)

### Model W0

- Wire.
- 14 grooved wire rolls for two plane straightening.
- Units separate easily for loading.

CAD files are available upon request.

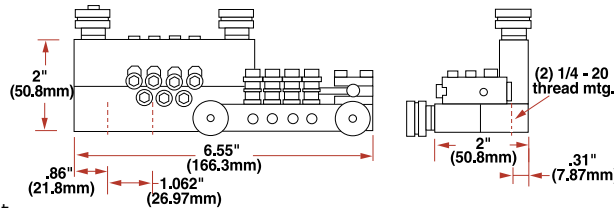

### Model W1 and W2

- Wire.
- 10 grooved wire rolls for two plane straightening.

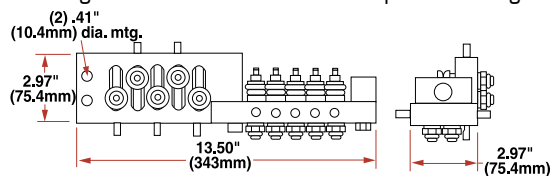

CAD files are available upon request.



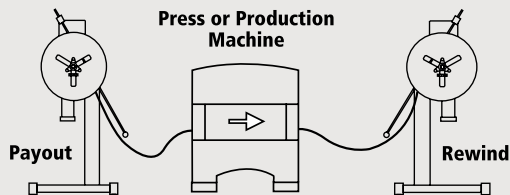

## 100 SERIES STOCK REELS

THE MOST COMPLETE SELECTION AVAILABLE FROM ANY SOURCE.  
POWERED AND NON-POWERED. ADJUSTABLE AND FIXED CENTERS.

### Powered reels.

Powered reels are made for ease of operation with innovative standard features such as our proportional control system. This top-of-the-line patented system features variable speed capability, electronic loop height adjustment and loop sensing arm range control.



**R24A  
POWERED REEL**



**R46NA  
NON-POWERED  
REEL**

### \* Non-powered.

Non-powered reels are available in all sizes, 50 lbs. (22kg) capacity to 500 lbs. (227kg) capacity. All have adjustable mechanical drag brakes. Add NF for non-powered fixed center or NA for non-powered adjustable center.

MODEL	MAX COIL WEIGHT	MAX COIL OD	MAX MATERIAL WIDTH	COIL I.D. RANGE	MAX SPEED (POWERED)	RATED LINE SPEED (POWERED)
<b>POWERED WITH ADJUSTABLE CENTER</b>						
R23A	75 lbs (34 kg)	18" (457 mm)	4" (102 mm)	3" - 12" (76 - 305 mm)	80 rpm	60 ft/min
R24A		24" (610 mm)				
R25A		30" (762 mm)				
R34A	150 lbs (68 kg)	24" (610 mm)	4" (102 mm)	5" - 16" (127 - 406 mm)	50 rpm	64 ft/min
R35A		30" (762 mm)				
R36A		36" (915 mm)				
R45A	250 lbs (114 kg)	30" (762 mm)	6" (152 mm)	9" - 20" (229 - 508 mm)	50 rpm	115 ft/min
R46A		36" (915 mm)				
R56A	500 lbs (227 kg)	36" (915 mm)	6" (152 mm)	9" - 20" (229 - 508 mm)	33 rpm	75 ft/min
R58A		48" (1,220 mm)				
<b>POWERED WITH FIXED CENTER</b>						
R23F	75 lbs (34 kg)	18" (457 mm)	4" (102 mm)	3/4" (19 mm)	80 rpm	60 ft/min
R24F		24" (610 mm)				
R25F		30" (762 mm)				
R34F	150 lbs (68 kg)	24" (610 mm)	4" (102 mm)	1-1/2" (38 mm)	50 rpm	64 ft/min
R35F		30" (762 mm)				
R36F		36" (915 mm)				
R45F	250 lbs (114 kg)	30" (762 mm)	6" (152 mm)	1-1/2" (38 mm)	50 rpm	115 ft/min
R46F		36" (915 mm)				
R56F	500 lbs (227 kg)	36" (915 mm)	6" (152 mm)	1-3/4" (44.5 mm)	33 rpm	75 ft/min
R58F		48" (1,220 mm)				

# STOCK REELS

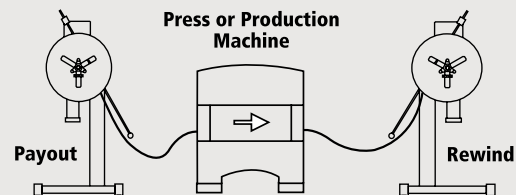

## 100 SERIES SINGLE HYDRAULIC STOCK REELS

The smooth running capability of our hydraulic reel means superior performance when handling delicate materials. The light tensioning capability offers an outstanding alternative for difficult rewind applications.



MODEL	MAX COIL WEIGHT	MAX COIL OD	MAX MATERIAL WIDTH	COIL I.D. RANGE	MAX SPEED (POWERED)
<b>HYDRAULIC ADJUSTABLE CENTER</b>					
RH34A	150 lbs (68 kg)	24" (610 mm)	4" (102 mm)	5" - 16" (127 - 406 mm)	80 rpm
RH35A		30" (762 mm)			
RH36A		36" (915 mm)			
RH45A	250 lbs (114 kg)	30" (762 mm)	6" (152 mm)	9" - 20" (229 - 508 mm)	80 rpm
RH46A		36" (915 mm)			
RH56A	400 lbs (182 kg)	36" (915 mm)	6" (152 mm)	9" - 20" (229 - 508 mm)	70 rpm
RH58A		48" (1,220 mm)			

MODEL	MAX COIL WEIGHT	MAX COIL OD	MAX MATERIAL WIDTH	CENTER SHAFT DIAMETER	MAX SPEED (POWERED)
<b>HYDRAULIC FIXED CENTER</b>					
RH34F	150 lbs (68 kg)	24" (610 mm)	4" (102 mm)	1-1/2" (38 mm)	80 rpm
RH35F		30" (762 mm)			
RH36F		36" (915 mm)			
RH45F	250 lbs (114 kg)	30" (762 mm)	6" (152 mm)	1-1/2" (38 mm)	80 rpm
RH46F		36" (915 mm)			
RH56F	400 lbs (182 kg)	36" (915 mm)	6" (152 mm)	1-3/4" (44.5 mm)	70 rpm
RH58F		48" (1,220 mm)			

MODEL	A	B	C
<b>POWERED REELS (ADJUSTABLE &amp; FIXED CENTER)</b>			
R23A(F)	34-7/16" (875 mm)	23-7/8" (607 mm)	20-1/8" (511 mm)
R24A(F)			
R25A(F)			
R34A(F)	34-7/16" (875 mm)	23-7/8" (607 mm)	25-1/8" (638 mm)
R35A(F)			
R36A(F)			
R45A(F)	34-7/16" (875 mm)	23-7/8" (607 mm)	25-1/8" (638 mm)
R46A(F)			
R56A(F)	34-7/16" (875 mm)	28"	25-1/8" (638 mm)
R58A(F)		711 mm	

MODEL	A	B	C
<b>NON POWERED REELS (ADJUSTABLE &amp; FIXED CENTER)</b>			
R23NA(F)	32-3/4" (832 mm)	23-7/8" (607 mm)	20-1/8" (511 mm)
R24NA(F)			
R25NA(F)			
R34NA(F)	32-3/4" (832 mm)	23-7/8" (607 mm)	20-1/8" (511 mm)
R35NA(F)			
R36NA(F)			
R45NA(F)	32-3/4" (832 mm)	23-7/8" (607 mm)	20-1/8" (511 mm)
R46NA(F)			
R56NA(F)	34-7/16" (875 mm)	28"	25-1/8" (638 mm)
R58NA(F)		711 mm	

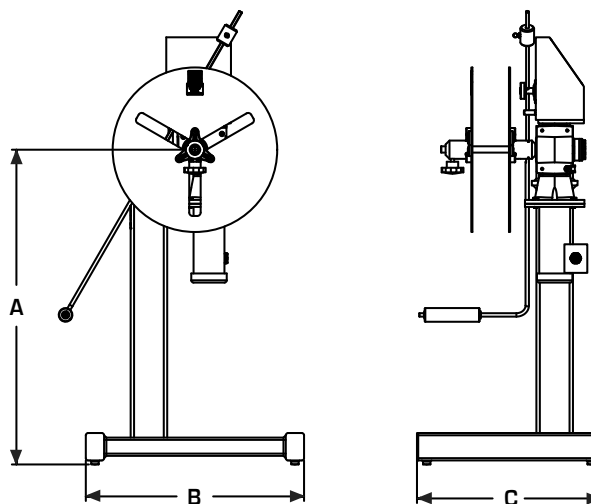

MODEL	A	B	C
<b>HYDRAULIC REELS (ADJUSTABLE &amp; FIXED CENTER)</b>			
RH34A(F)	33-3/4" (857 mm)	23-7/8" (607 mm)	20-1/8" (511 mm)
RH35A(F)			
RH36A(F)			
RH45A(F)	33-3/4" (857 mm)	23-7/8" (607 mm)	20-1/8" (511 mm)
RH46A(F)			
RH56A(F)	34"	23-7/8" (607 mm)	25-1/8" (638 mm)
RH58A(F)			864 mm

CAD files are available upon request.

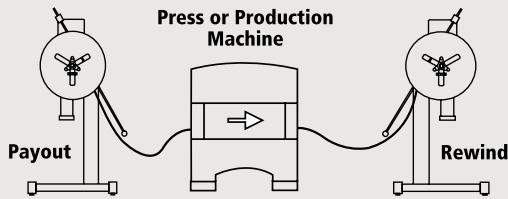

## 1000 SERIES SINGLE STOCK REELS

POWERED AND NON-POWERED. ADJUSTABLE AND FIXED. WITH OR WITHOUT BRAKES.

- Max. capacities 1,500-6,000 lbs. (682-2727kg)
- Inner coil plates or keeper arms are options on both variable speed powered and non-powered models
- Hold down arms optional
- Hydraulic expansion optional



**RA4012 WITH PNEUMATIC HOLD DOWN**

MODEL	MAX COIL WEIGHT	MAX COIL OD	MAX MATERIAL WIDTH	COIL I.D. RANGE	MAX SPEED (POWERED)	RATED LINE SPEED (POWERED)	MOTOR SIZE	AC POWER REQUIRED
<b>SINGLE CABINET ADJUSTABLE CENTER</b>								
RA1512	1,500 lbs (682 kg)	48" (122 cm)	12" (31 cm)	14" - 22" (36 - 56 cm)	23 rpm	84 ft/min	3/4 hp	115 vac single phase
RA2506	2,500 lbs (1,136 kg)	60" (152 cm)	6" (15 cm)	16" - 24" (41 - 61 cm)	23 rpm	96 ft/min	1 hp	115 vac single phase
RA2512			12" (31 cm)					
RA2518			18" (46 cm)					
RA4012	4,000 lbs (1,818 kg)	60" (152 cm)	12" (31 cm)	16" - 24" (41 - 61 cm)	23 rpm	96 ft/min	1-1/2 hp	230 vac single phase
RA4018			18" (46 cm)					
RA4024			24" (61 cm)					
RA6012	6,000 lbs (2,727 kg)	72" (183 cm)	12" (31 cm)	17" - 24" (46 - 61 cm)	17 rpm	75 ft/min	2 hp	230 vac single phase
RA6018			18" (46 cm)					
RA6024			24" (61 cm)					

MODEL	MAX COIL WEIGHT	MAX COIL OD	MAX MATERIAL WIDTH	COIL I.D. RANGE	AC POWER REQUIRED	
<b>SINGLE CABINET ADJUSTABLE CENTER (NON POWERED AIR DRAG BRAKE)</b>						
RPA1512	1,500 lbs (682 kg)	48" (122 cm)	12" (31 cm)	14" - 22" (36 - 56 cm)	RPA1512 115 vac, 60 hz single phase	
RPA2506			6" (15 cm)			16" - 24" (41 - 61 cm)
RPA2512						
RPA2518	18" (46 cm)					
RPA4012	4,000 lbs (1,818 kg)	60" (152 cm)	12" (31 cm)	16" - 24" (41 - 61 cm)	RPA2506 thru RPA6024 230 vac, 60hz single phase	
RPA4018			18" (46 cm)			
RPA4024			24" (61 cm)			
RPA6012	6,000 lbs (2,727 kg)	72" (183 cm)	12" (31 cm)	17" - 24" (46 - 61 cm)	if equipped with hydraulic expansion	
RPA6018			18" (46 cm)			
RPA6024			24" (61 cm)			
<b>SINGLE CABINET ADJUSTABLE CENTER (NON POWERED MECHANICAL BRAKE)</b>						
RMA1512	1,500 lbs (682 kg)	48" (122 cm)	12" (31 cm)	14" - 22" (36 - 56 cm)	—	

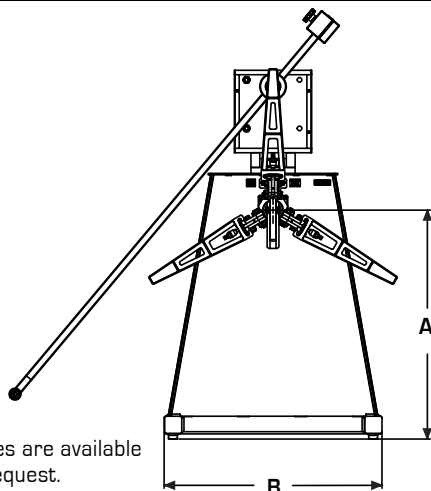

CAD files are available upon request.

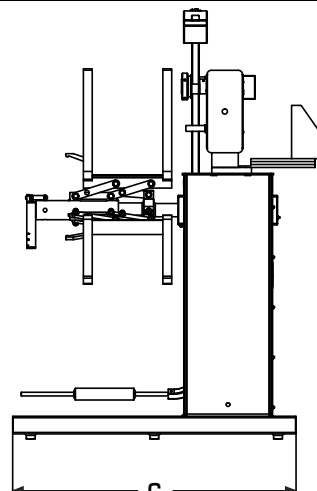

MODEL	A	B	C
<b>SINGLE CABINET ADJUSTABLE CENTER</b>			
RA1512	38-7/8" (987 mm)	37" (940 mm)	48-1/8" (1222 mm)
RA2506	39-7/8" (1013 mm)	45" (1143 mm)	60-1/8" (1527 mm)
RA2512			
RA2518			
RA4012	39-7/8" (1013 mm)	45" (1143 mm)	60-1/8" (1527 mm)
RA4018			
RA4024			
RA6012	42-7/8" (1089 mm)	58" (1473 mm)	71-3/4" (1822 mm)
RA6018			
RA6024			

# SPECIALTY STOCK REELS

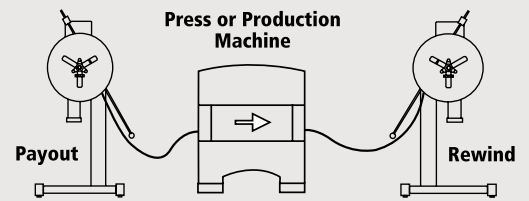

## 100 SERIES NON-POWERED SINGLE REEL WITH STRAIGHTENER

SAVE FLOOR SPACE AND MAXIMIZE PRODUCTION WITH A RAPID-AIR REEL/STRAIGHTENER COMBO. NON-POWERED.

Max. capacities  
150-500 lbs.  
(68-227kg).

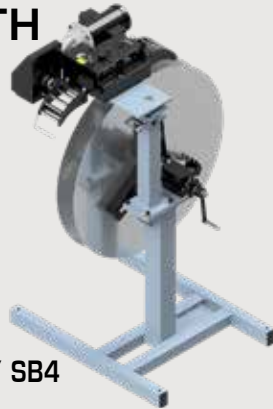

R36NA / SB4

MODEL	MAX COIL WEIGHT	MAX COIL OD	MAX MATERIAL WIDTH
REEL/STRAIGHTENER WITH SB4			
R34NA/SB4	150 lbs (68 kg)	24" (610 mm)	4" (102 mm)
R35NA/SB4		30" (762 mm)	
R36NA/SB4		36" (915 mm)	
R45NA/SB4	250 lbs (114 kg)	30" (762 mm)	4" (102 mm)
R46NA/SB4		36" (915 mm)	
R56NA/SB4	500 lbs (227 kg)	36" (915 mm)	4" (102 mm)
R58NA/SB4		48" (1,220 mm)	

## 1000 SERIES NON-POWERED SINGLE REEL WITH STRAIGHTENER

NON-POWERED REEL AND POWERED STRAIGHTENER. RIGHT OR LEFT PAYOUT.

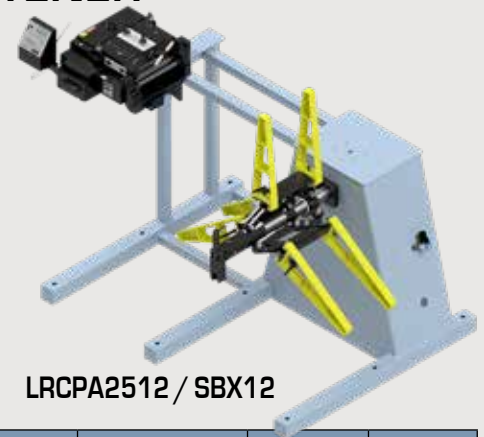

LRCPA2512 / SBX12

ADJUSTABLE CENTER MODEL	DRAG BRAKE	MAX COIL WEIGHT	MAX COIL OD	MAX MATERIAL WIDTH
SINGLE NON-POWERED REEL WITH STRAIGHTENER				
LCRPA1512/SBX8	Air	1,500 lbs (682 kg)	48" (122 cm)	8" (15 cm)
LCRPA1512/SBX12	Air			12" (31 cm)
LCRPA2506/SCX6	Air	2,500 lbs (1136 kg)	60" (152 cm)	6" (15 cm)

## 100 SERIES DUAL SWIVEL REELS

SAVE VALUABLE PRODUCTION TIME WITH DUAL SWIVEL REELS. POWERED AND NON-POWERED.

Max. capacities 150-500 lbs. (68-227kg).

MODEL	MAX COIL WEIGHT (PER SIDE)	MAX COIL OD	MAX MATERIAL WIDTH	COIL I.D. RANGE	MAX SPEED (POWERED)	RATED LINE SPEED (POWERED)
POWERED WITH ADJUSTABLE CENTER						
RS34A	150 lbs (68 kg)	24" (610 mm)	4" (102 mm)	5" - 16" (127 - 406 mm)	50 rpm	64 ft/min
RS35A		30" (762 mm)				
RS36A		36" (915 mm)				
RS45A	250 lbs (114 kg)	30" (762 mm)	6" (152 mm)	9" - 20" (229 - 508 mm)	50 rpm	115 ft/min
RS46A		36" (915 mm)				
RS56A	500 lbs (227 kg)	36" (915 mm)	6" (152 mm)	9" - 20" (229 - 508 mm)	33 rpm	75 ft/min
RS58A		48" (1,220 mm)				

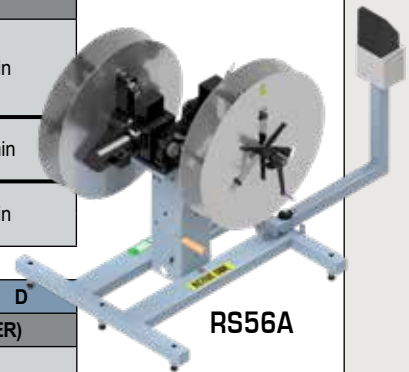

RS56A

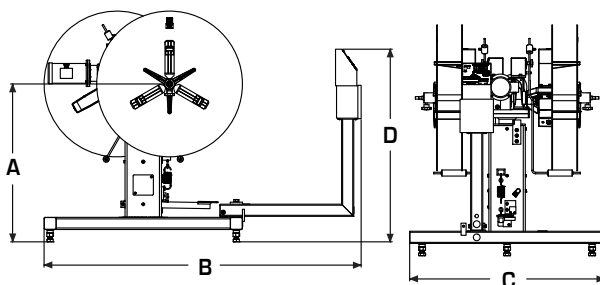

MODEL	A	B	C	D
DUAL SWIVEL (ADJUSTABLE & FIXED CENTER)				
R34A(F)	37-7/8" (962 mm)	78-5/16" (1989 mm)	48-1/8" (1222 mm)	47-9/16" (1208 mm)
R35A(F)				
R36A(F)				
R45A(F)	37-7/8" (962 mm)	78-5/16" (1989 mm)	48-1/8" (1222 mm)	47-9/16" (1208 mm)
R46A(F)				
R56A(F)	39" (991 mm)	78-5/16" (1989 mm)	48-1/8" (1222 mm)	47-9/16" (1208 mm)
R58A(F)				

CAD files are available upon request.

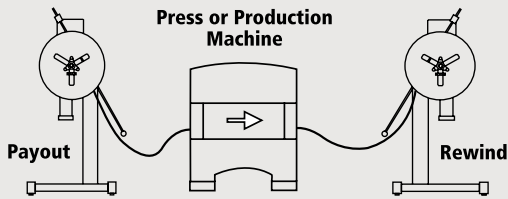

## 1000 SERIES DUAL SWIVEL REELS

FOR HEAVY-DUTY COIL HANDLING.  
VARIABLE SPEED POWERED AND NON-POWERED.  
HYDRAULIC EXPANSION AND BRAKES.

- Max. capacities  
1,500-6,000 lbs. (682-2727kg)
- Inner coil plates or keeper arms are options on both variable speed powered and non-powered models
- Hold down arms optional
- Hydraulic expansion optional

RHSPA4012  
WITH POWERED  
ROTATE



## RIM DRIVE PAYOUT REELS

ALLOWS PAYOUT FROM EITHER  
PRESS SIDE OR BACKSIDE OF REEL

MODEL	MAX COIL WEIGHT	MAX COIL OD	MIN COIL OD	MAX MATERIAL WIDTH	RATED LINE SPEED (IN/MIN)	MOTOR SIZE
SINGLE NON-POWERED REEL WITH STRAIGHTENER						
RD317S	3,000 lbs (1361 kg)	40"	18"	17"	2,400" (60m)	1/2 hp
RD417M	4,000 lbs (1814 kg)	(1016 mm)	(457 mm)	(457 mm)	3,600" (91m)	1 hp

Straighteners or power rolls may be added for space saving.

RD3175

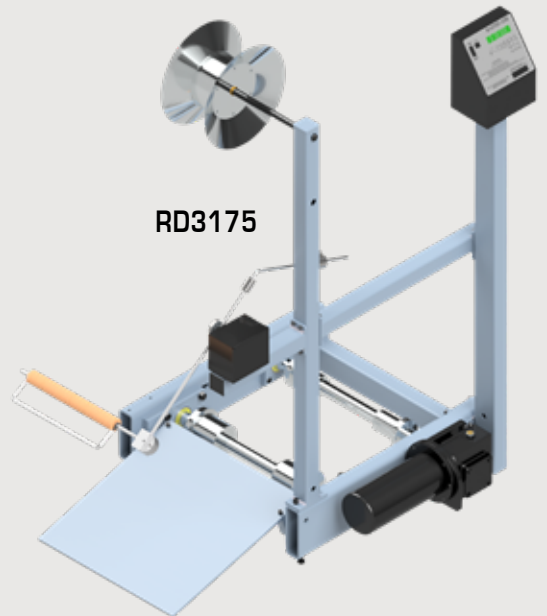

## MODULAR MULTI-HEAD REEL COMBINATIONS

MULTI-HEAD REEL COMBINATIONS  
PROVIDE PAYOUT AND REWINDING  
CAPABILITIES AND INTERLEAF PROTECTION

Any number of multi-head setups can be put in place to accommodate your manufacturing needs. Consult factory for special arrangements.

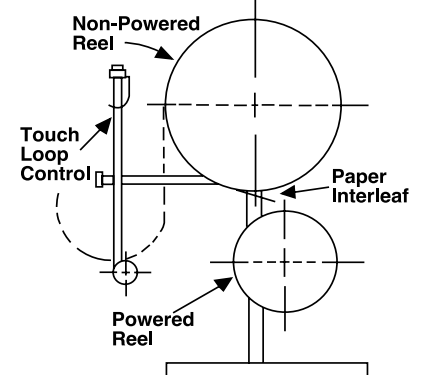

Typical dual reel setup when paper interleaf is required.

# CUTTERS

## RECIPROCATING CUTTERS (FSC)

Rapid-Air offers a full range of pneumatic stock cutters that provide outstanding application flexibility and efficiency in handling your routine or specialty shearing and cut-to-length jobs.



MODEL	MAX STOCK WIDTH	MAX THICKNESS CAPACITY	CUTTER BLADE OPENING	MAX FORCE @ 100 PSI
<b>RECIPROCATING FLAT STOCK CUTTER SPECIFICATIONS</b>				
FSC4	4" (102 mm)	.040" (1.02 mm)	.150" (3.81 mm)	1,200 lbs (545 kg)
FSC6	6" (152 mm)	.046" (1.17 mm)	.180" (4.57 mm)	2,000 lbs (509 kg)
FSC12	12" (305 mm)	.068" (1.73 mm)	.100" (2.54 mm)	4,000 lbs (1,818 kg)
FSC18	18" (457 mm)	.080" (2.03 mm)	.180" (4.57 mm)	3,000/6,000 lbs (1,365/2,727 kg)
FSC24	24" (610 mm)	.090" (2.29 mm)	.090" (2.29 mm)	4,000/8,000 lbs (1,818/3,636 kg)

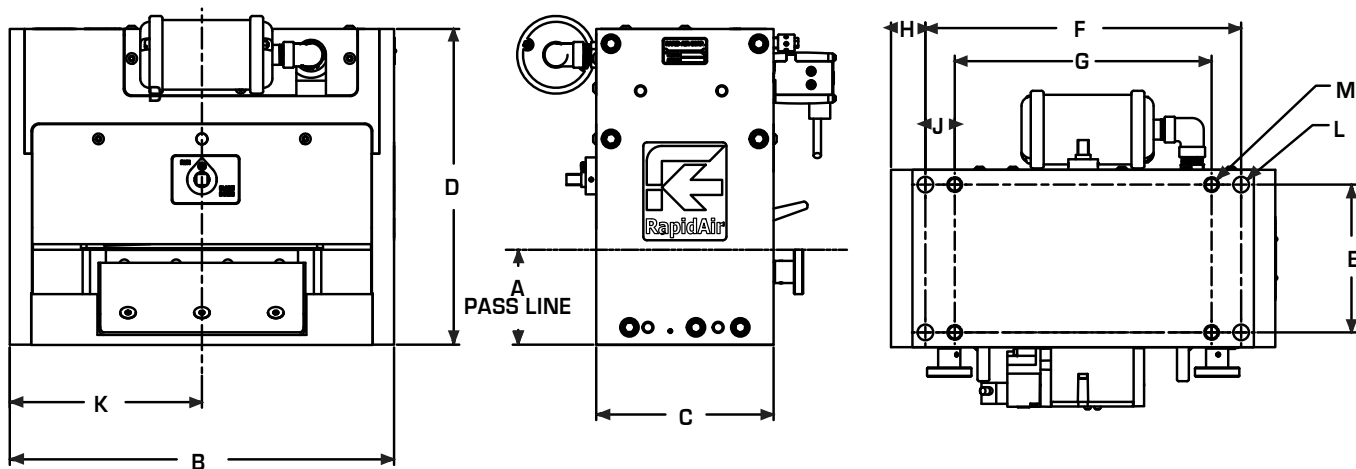

MODEL	A	B	C	D	E	F	G	H	J	K	SCREW SIZE L	TAPPED HOLE SIZE M
<b>RECIPROCATING FLAT STOCK CUTTERS DIMENSIONS</b>												
FSC4	3.22" (82 mm)	10-7/16" (265 mm)	6" (152 mm)	10-11/16" (271 mm)	5" (127 mm)	8" (203 mm)	6" (152 mm)	1-1/4" (32 mm)	1"	5-1/4" (133 mm)	1/2"	1/2-13
FSC6		13" (330 mm)				10-11/16" (271 mm)	8-11/16" (221 mm)	1-3/16" (30 mm)		6-1/2" (165 mm)		
FSC12	4.44" (113 mm)	22" (559 mm)	7" (178 mm)	13-13/16" (351 mm)	6" (152 mm)	17" (432 mm)		2-1/2" (64 mm)		11" (279 mm)		3/4-10
FSC18	6.95" (177 mm)	29" (737 mm)	10-3/4" (273 mm)	20-9/16" (522 mm)	9-1/4" (235 mm)	25" (635 mm)	—	2" (51 mm)	—	14-1/2" (368 mm)	5/8"	—
FSC24		35" (889 mm)				31" (787 mm)				17-1/2" (445 mm)		

CAD files are available upon request.



## PIVOT ARM CUTTERS



MODEL	MAX STOCK WIDTH	MAX THICKNESS CAPACITY	CUTTER BLADE OPENING	MAX FORCE
<b>PIVOT CUTTER SPECIFICATIONS</b>				
SCR125	1-1/4"	.040"	.135"	1,400 lbs (636 kg)
SCL125	(32 mm)	(1.02 mm)	(3.43 mm)	
RSC14	.170" dia. (4.32 mm dia.)		.200" (5.08 mm)	1,400 lbs (636 kg)
RSC25	.188" (4.75 mm)		.312" (7.92 mm)	2,500 lbs (1136 kg)

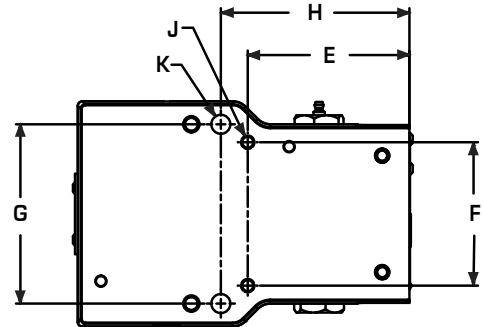
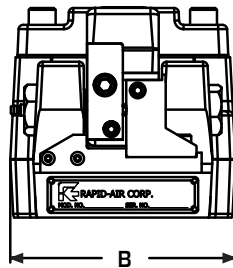
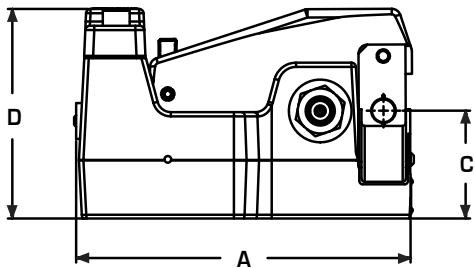

MODEL	A	B	C	D	E	F	G	H	SCREW SIZE K	TAPPED HOLE SIZE J
<b>PIVOT CUTTER DIMENSIONS</b>										
SCR125	7-15/16"	5-3/4"	3"	5-1/2"	3-13/16"	4"	4-11/16"	4-1/2"	3/8"	3/8-16
SCL125										
RSC14	8-1/8"	5-3/4"	3"	5-1/2"	3-7/8"	4"	4-11/16"	4-9/16"	3/8"	3/8-16
RSC25	9-5/16"	6-1/4"		5-7/8"	4-1/2"	4"	5"	5-1/4"	1/2"	

CAD files are available upon request.

# CUT-TO-LENGTH

## C-T-L MACHINES

ACCURATE, AUTOMATED STOCK CUTTING FOR PRECISE, HIGH-SPEED, AND HIGH VOLUME REPETITIVE JOBS

CTL Lines available for widths up to 24". Consult factory for your needs.

- Air Feed CTL
- Servo Feed CTL
- Servo Straightener CTL
- Wire Servo CTL



FSC12S + 112T CTL

## LOOP CONTROLS

PROPORTIONAL ELECTRONIC LOOP CONTROL SYSTEM IS STANDARD FOR POWERED MODELS (EXCEPT 100 SERIES HYDRAULIC REELS)

### MODEL RS3

Optional ultrasonic non-contact loop control

Automatically adjusts the operating speed of a powered reel to maintain a free material loop and to match material flow to a required line speed. No moving parts, no stock contact, no loop sensing arm, mechanical linkage or other hardware. Works with equal precision for both conductive and non-conductive materials.



External loop control port included with all powered reels and straighteners

Our standard loop control for Rapid-Air power products is a pushbutton unit with digital display. This very flexible proportional control allows fine setting of speed, loop angle and loop height. A remote or external loop sensor may be plugged directly into this control as an alternate loop control.



### MODEL RTB

Optional electronic hi-lo touch system loop control

The Rapid-Touch system works without use of a material sensing arm by sensing the upper and lower position of conductive material. For use with non-conductive material, an adjustable probe is furnished on the inside of the large diameter, flexible sensors. As the material ranges between the sensors, a solid state controller automatically sets the most uniform line speed for continuous operation and changes this speed to match variable requirements.

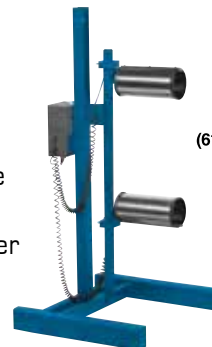

CAD files are available upon request.

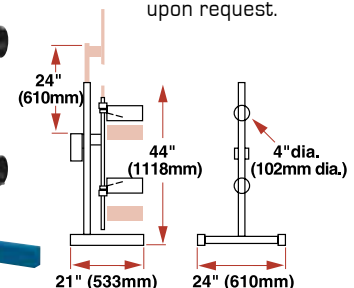

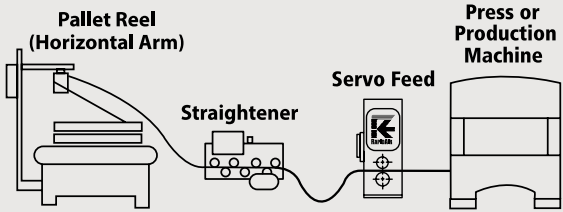

# PALLET REELS

## HORIZONTAL ARM

WITH OR WITHOUT STRAIGHTENER. LOW COST SOLUTION WITH HORIZONTAL SENSING ARM.

The ideal low cost pallet decoiler. Features easy set up and thread up. The free motion material guide roll automatically seeks the best position for material transition and guiding.



MODEL	MAX COIL WEIGHT	MAX COIL OD	MAX MATERIAL WIDTH	MAX MATERIAL THICKNESS	MAX COIL HEIGHT	MAX SPEED	MOTOR SIZE	AC POWER REQUIRED
PMDH35	3,500 lbs (1591 kg)	36" (914 mm)	4" (101 mm)	.050" (1.27 mm)	30" (762 mm)	20 rpm	1 hp	115 vac single phase
PMDH50	5,000 lbs (2272 kg)	50" (1270 mm)	6" (152 mm)					230 vac single phase
PMDH100	10,000 lbs (4545 kg)						2 hp	

### PMDH35

MODEL	A	B	C	D
PMDH35	62" (1575 mm)	64-1/2" (1638 mm)	33-3/4" (857 mm)	37" dia (940 mm)

### PMDH50 & PMDH100

MODEL	A	B	C	D
PMDH50	64" (1626 mm)	68-3/4" (1746 mm)	57-1/2" (1461 mm)	51" dia (1295 mm)
PMDH100				

CAD files are available upon request.

## ■ SPECIAL REQUIREMENTS

WE OFFER CUSTOM MECHANICAL  
AND PROGRAMMING SOLUTIONS.  
CONTACT FACTORY FOR  
SPECIAL REQUEST.  
SALES@RAPIDAIR.COM



MANUFACTURED &  
ASSEMBLED IN THE USA  
SINCE 1959

### PRODUCT SPECIFICATIONS:

All product specifications are subject to change without prior notice.  
Rapid-Air Corp. will provide up-dated technical data and specifications  
on any product upon written request.



**MOST RELIABLE FEEDING & COIL HANDLING EQUIPMENT MADE**



RAPID-AIR CORP. • 4601 Kishwaukee Street • Rockford, IL 61109-2925  
Phone: (815) 397-2578 • Fax: (815) 398-3887 • Website: [www.rapidair.com](http://www.rapidair.com) • Email: [sales@rapidair.com](mailto:sales@rapidair.com)